



Air Conditioning & Heating

GSZC16

COOLING CAPACITY: 24,000 - 60,000 BTU/H

HEATING CAPACITY: 24,000 - 60,000 BTU/H

HIGH-EFFICIENCY SPLIT SYSTEM HEAT PUMP UP TO 17 SEER & 9.5 HSPF



Contents

Nomenclature.....	2
Product Specifications.....	3
Expanded Cooling Data.....	4
Expanded Heating Data.....	20
Dimensions.....	22
Wiring Diagram.....	23
Accessories.....	26

Standard Features

- Two-Stage Copeland® UltraTech™ scroll compressor
- High-density foam compressor sound blanket
- Integrated communicating ComfortBridge™ Technology
- Commissioning and diagnostics via indoor board Bluetooth with the CoolCloud™ phone and tablet application
- Expanded ComfortAlert™ diagnostics built in
- Set-up capable with two low-voltage wires to outdoor unit
- Diagnostic indicator lights and storage of six fault codes
- Color-coded terminal strip for non-communicating set-up
- SmartShift® technology to ensure quiet, reliable defrost
- Factory-installed bi-flow liquid-line filter drier
- Factory-installed transformer
- Factory-installed suction-line accumulator
- Factory-installed compressor crankcase heater
- Factory-installed high-capacity muffler
- Factory-installed coil and ambient temperature sensors
- High- and low-pressure switches
- Fully charged for 15' of tubing length
- Two-speed quiet condenser fan motor
- Sweat connection service valves with easy access to gauge ports
- AHRI Certified; ETL Listed

Cabinet Features

- Goodman® brand sound control top design
- Heavy-gauge galvanized-steel cabinet
- Appliance-quality powder-paint finish with 500-hour salt-spray approval
- Wire fan discharge grille
- Steel louver coil guard
- Rust-resistant coated screws
- Compact footprint
- Top and side maintenance access
- Single-panel access to controls with space provided for field-installed accessories
- When properly anchored, meets 2017 Florida Building Code unit integrity requirements for hurricane-type winds (Anchor bracket kits available.)







Proper sizing and installation of equipment is critical to achieve optimal performance. Split system air conditioners and heat pumps must be matched with appropriate coil components to meet ENERGY STAR® criteria. Ask your contractor for details or visit www.energystar.gov.

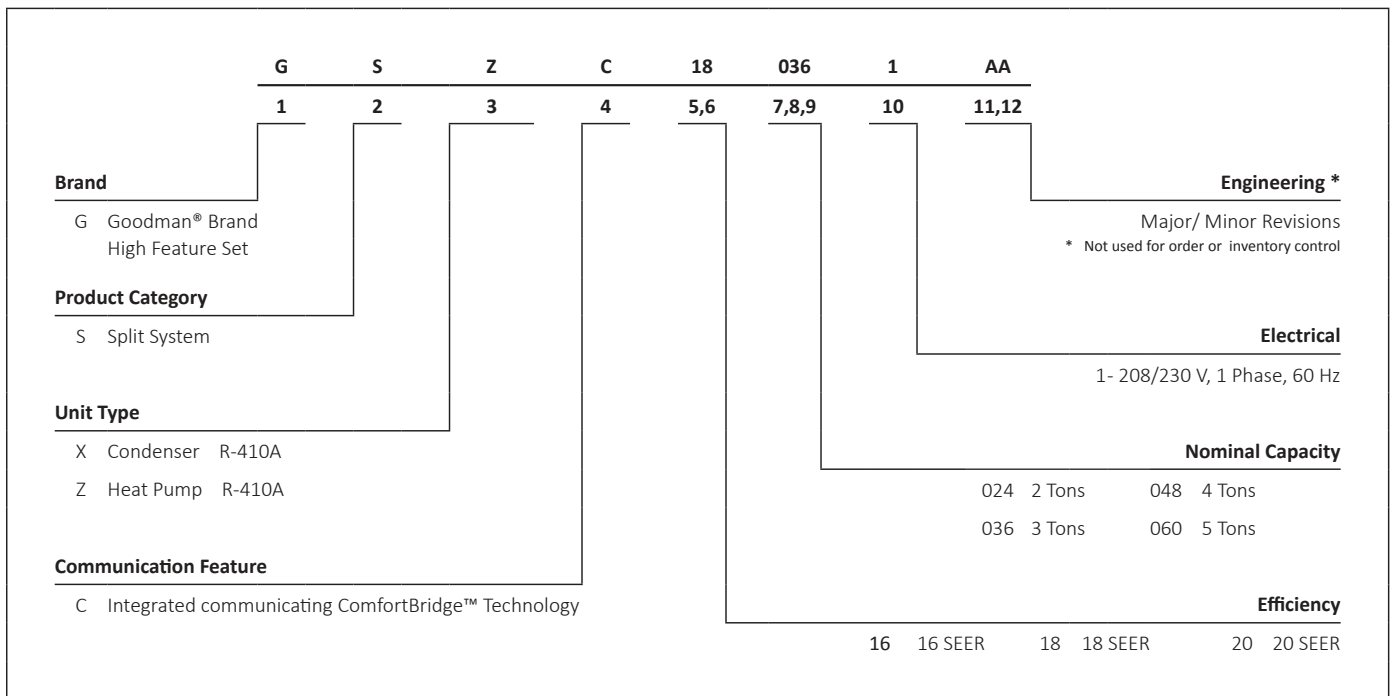

* Complete warranty details available from your local dealer or at www.goodmanmfg.com. To receive the Lifetime Compressor Limited Warranty (good for as long as you own your home), 10-Year Unit Limited Warranty, and 10-Year Parts Limited Warranty, online registration must be completed within 60 days of installation. Online registration is not required in California or Québec.



	GSZC16 0241C	GSZC16 0361C	GSZC16 0481C	GSZC16 0601C
CAPACITIES AND RATINGS				
Nominal Cooling (BTU/h)	24,000	36,000	48,000	60,000
Nominal Heating (BTU/h)	24,000	36,000	48,000	60,000
Decibels	73	73	75	75
COMPRESSOR				
RLA	10.0	14.8	20.4	22.9
LRA	62.9	84.2	122.1	147.2
CONDENSER FAN MOTOR				
Horsepower	1/5	1/5	1/5	1/3
FLA	1.0	1.0	1.0	2.8
REFRIGERATION SYSTEM				
Refrigerant Line Size ¹				
Liquid Line Size ("O.D.)	3/8"	3/8"	3/8"	3/8"
Suction Line Size ("O.D.)	3/4"	7/8"	1 1/8"	1 1/8"
Refrigerant Connection Size				
Liquid Valve Size ("O.D.)	3/8"	3/8"	3/8"	3/8"
Suction Valve Size ("O.D.)	3/4"	7/8"	7/8"	7/8"
Valve Connection Type	Sweat	Sweat	Sweat	Sweat
Refrigerant Charge (oz.)	176	170	244	288
Shipped with Orifice Size	NA	NA	NA	NA
ELECTRICAL DATA				
Volts-Hz	208/230-60	208/230-60	208/230-60	208/230-60
Minimum Circuit Ampacity ²	13.5	19.5	26.5	31.4
Max. Overcurrent Protection ³	20	30	45	50
Min / Max Volts	197/253	197/253	197/253	197/253
Power Supply Conduit Size	1/2" or 3/4"	1/2" or 3/4"	1/2" or 3/4"	1/2" or 3/4"
UNIT WEIGHTS				
Equipment Weight	215	240	291	313
Ship Weight (lbs)	240	266	316	339
ENERGY STAR CERTIFIED [^]				
				

[^] Proper sizing and installation of equipment is critical to achieve optimal performance. Split system air conditioners and heat pumps must be matched with appropriate coil components to meet ENERGY STAR[®] criteria. Ask your contractor for details or visit www.energystar.gov. The www.energystar.gov website provides up-to-date system combinations certified to meet ENERGY STAR[®] requirements.

¹ Tested and rated in accordance with AHRI Standard 210/240

² Wire size should be determined in accordance with National Electrical Codes; extensive wire runs will require larger wire sizes

³ Must use time-delay fuses or HACR-type circuit breakers of the same size as noted.

NOTES

- Always check the rating plate for electrical data on the unit being installed.
- Installer will need to supply 3/8" to 1 1/8" adapters for suction line connections.
- Unit is charged with refrigerant for 15' of 3/8" liquid line. System charge must be adjusted per Installation Instructions Final Charge Procedure.
- Installation of these units requires the specified TXV Kit to be installed on the indoor coil.
THE SPECIFIED TXV IS DETERMINED BY THE OUTDOOR UNIT, NOT THE INDOOR COIL.

IDB	AIRFLOW	OUTDOOR AMBIENT TEMPERATURE																							
		65°F				75°F				85°F				95°F				105°F				115°F			
		59	63	67	71	59	63	67	71	59	63	67	71	59	63	67	71	59	63	67	71	59	63	67	71
70	MBh	17.7	18.0	18.5	-	17.6	17.8	18.3	-	17.1	17.4	17.9	-	16.3	16.6	17.1	-	15.4	15.6	16.1	-	14.5	14.7	15.3	-
	S/T	0.66	0.59	0.45	-	0.67	0.60	0.46	-	0.70	0.62	0.48	-	1.00	0.64	0.50	-	1.00	0.66	0.53	-	1.00	0.71	0.58	-
	ΔT	19	17	14	-	19	17	14	-	19	17	14	-	19	17	14	-	19	17	13	-	20	18	15	-
	kW	0.75	0.75	0.75	-	0.84	0.84	0.84	-	0.93	0.93	0.93	-	1.03	1.03	1.03	-	1.15	1.15	1.15	-	1.28	1.28	1.28	-
	Amps	3.3	3.2	3.2	-	3.6	3.6	3.6	-	4.1	4.1	4.1	-	4.5	4.5	4.5	-	5.1	5.1	5.0	-	5.7	5.7	5.7	-
	Hi PR	188	189	190	-	217	218	219	-	248	249	250	-	281	282	283	-	317	318	319	-	355	356	357	-
	Lo PR	129	130	133	-	136	138	141	-	143	145	148	-	149	150	154	-	154	156	159	-	161	163	166	-
	MBh	18.1	18.3	18.8	-	17.9	18.2	18.7	-	17.5	17.7	18.2	-	16.7	16.9	17.4	-	15.7	16.0	16.5	-	14.8	15.1	15.6	-
	S/T	0.70	0.63	0.49	-	0.71	0.63	0.50	-	1.00	0.66	0.52	-	1.00	0.68	0.54	-	1.00	0.70	0.56	-	1.00	1.00	0.62	-
	ΔT	18	16	13	-	18	16	13	-	18	16	13	-	18	16	12	-	18	16	12	-	19	17	13	-
kW	0.76	0.76	0.76	-	0.84	0.84	0.84	-	0.94	0.94	0.93	-	1.04	1.04	1.04	-	1.15	1.15	1.15	-	1.29	1.28	1.28	-	
Amps	3.3	3.3	3.3	-	3.7	3.7	3.6	-	4.1	4.1	4.1	-	4.6	4.6	4.5	-	5.1	5.1	5.1	-	5.7	5.7	5.7	-	
Hi PR	190	191	192	-	219	220	221	-	250	251	252	-	283	284	285	-	319	320	321	-	357	358	359	-	
Lo PR	131	133	136	-	139	140	144	-	146	147	150	-	151	153	156	-	157	159	162	-	164	166	169	-	
MBh	18.5	18.7	19.3	-	18.3	18.6	19.1	-	17.9	18.1	18.6	-	17.1	17.3	17.9	-	16.1	16.4	16.9	-	15.2	15.5	16.0	-	
S/T	0.71	0.63	0.50	-	0.71	0.64	0.50	-	1.00	0.66	0.53	-	1.00	0.68	0.55	-	1.00	0.71	0.57	-	1.00	1.00	0.62	-	
ΔT	17	15	12	-	17	15	12	-	17	15	12	-	17	15	12	-	17	15	11	-	18	16	12	-	
kW	0.76	0.76	0.76	-	0.85	0.85	0.84	-	0.94	0.94	0.94	-	1.04	1.04	1.04	-	1.16	1.15	1.15	-	1.29	1.29	1.29	-	
Amps	3.3	3.3	3.3	-	3.7	3.7	3.7	-	4.1	4.1	4.1	-	4.6	4.6	4.6	-	5.1	5.1	5.1	-	5.7	5.7	5.7	-	
Hi PR	192	192	194	-	221	222	223	-	252	253	254	-	285	286	287	-	321	321	323	-	359	360	361	-	
Lo PR	134	136	139	-	142	143	147	-	149	150	153	-	154	156	159	-	160	161	165	-	167	168	172	-	

IDB	AIRFLOW	OUTDOOR AMBIENT TEMPERATURE																							
		65°F				75°F				85°F				95°F				105°F				115°F			
		59	63	67	71	59	63	67	71	59	63	67	71	59	63	67	71	59	63	67	71	59	63	67	71
75	MBh	17.7	18.0	18.5	19.3	17.6	17.8	18.4	19.2	17.1	17.4	17.9	18.7	16.3	16.6	17.1	17.9	15.4	15.6	16.1	16.9	14.5	14.7	15.3	16.1
	S/T	0.79	0.72	0.58	0.44	1.00	0.72	0.59	0.45	1.00	0.75	0.61	0.47	1.00	0.77	0.63	0.49	1.00	1.00	0.66	0.51	1.00	1.00	0.71	0.56
	ΔT	23	21	18	14	23	21	18	14	23	22	18	14	23	21	18	14	23	21	18	14	24	22	19	15
	kW	0.75	0.75	0.75	0.76	0.84	0.84	0.84	0.84	0.93	0.93	0.93	0.94	1.03	1.03	1.03	1.04	1.15	1.15	1.14	1.15	1.28	1.28	1.28	1.28
	Amps	3.2	3.2	3.2	3.3	3.6	3.6	3.6	3.7	4.1	4.1	4.1	4.1	4.5	4.5	4.5	4.6	5.1	5.0	5.0	5.1	5.7	5.7	5.7	5.7
	Hi PR	188	189	190	193	217	218	220	223	248	249	250	254	281	282	283	287	317	318	319	322	355	356	357	361
	Lo PR	129	130	133	139	136	138	141	147	143	145	148	153	149	150	154	159	154	156	159	165	161	163	166	172
	MBh	18.1	18.3	18.9	19.7	17.9	18.2	18.7	19.5	17.5	17.7	18.2	19.0	16.7	16.9	17.5	18.3	15.7	16.0	16.5	17.3	14.8	15.1	15.6	16.4
	S/T	0.83	0.76	0.62	0.48	1.00	0.76	0.63	0.48	1.00	0.79	0.65	0.51	1.00	0.81	0.67	0.53	1.00	1.00	0.69	0.55	1.00	1.00	0.74	0.60
	ΔT	22	20	17	13	22	20	17	13	22	20	17	13	22	20	17	13	22	20	16	13	23	21	18	14
kW	0.76	0.76	0.76	0.76	0.84	0.84	0.84	0.85	0.94	0.94	0.93	0.94	1.04	1.04	1.04	1.04	1.15	1.15	1.15	1.16	1.28	1.28	1.28	1.29	
Amps	3.3	3.3	3.3	3.3	3.7	3.7	3.6	3.7	4.1	4.1	4.1	4.1	4.6	4.5	4.5	4.6	5.1	5.1	5.1	5.1	5.7	5.7	5.7	5.7	
Hi PR	190	191	192	195	219	220	221	225	250	251	252	255	283	284	285	289	319	320	321	324	357	358	359	363	
Lo PR	131	133	136	141	139	141	144	149	146	147	150	156	151	153	156	162	157	159	162	167	164	166	169	174	
MBh	18.5	18.7	19.3	20.1	18.3	18.6	19.1	19.9	17.9	18.1	18.6	19.4	17.1	17.3	17.9	18.7	16.1	16.4	16.9	17.7	15.3	15.5	16.0	16.8	
S/T	1.00	0.76	0.63	0.48	1.00	0.77	0.63	0.49	1.00	0.79	0.66	0.51	1.00	1.00	0.68	0.53	1.00	1.00	0.70	0.56	1.00	1.00	0.75	0.61	
ΔT	21	19	16	12	21	19	16	12	21	19	16	12	21	19	16	12	21	19	15	12	22	20	17	13	
kW	0.76	0.76	0.76	0.77	0.85	0.84	0.84	0.85	0.94	0.94	0.94	0.94	1.04	1.04	1.04	1.05	1.15	1.15	1.15	1.16	1.29	1.29	1.29	1.29	
Amps	3.3	3.3	3.3	3.3	3.7	3.7	3.7	3.7	4.1	4.1	4.1	4.1	4.6	4.6	4.6	4.6	5.1	5.1	5.1	5.1	5.7	5.7	5.7	5.7	
Hi PR	192	193	194	197	221	222	223	227	252	253	254	257	285	286	287	290	321	322	323	326	359	360	361	364	
Lo PR	134	136	139	144	142	143	147	152	149	150	153	159	154	156	159	164	160	161	165	170	167	168	172	177	

IDB: Entering Indoor Dry Bulb Temperature
 High and low pressures are measured at the liquid and suction service valves.
 Shaded area reflects ACCA (TVA) conditions
 kW = Total system power
 Amps = outdoor unit amps (compressor + fan)

IDB	AIRFLOW	OUTDOOR AMBIENT TEMPERATURE												ENTERING INDOOR WET BULB TEMPERATURE													
		65°F				75°F				85°F				95°F				105°F				115°F					
		59	63	67	71	59	63	67	71	59	63	67	71	59	63	67	71	59	63	67	71	59	63	67	71		
80	520	MBh	17.8	18.1	18.6	19.4	17.7	17.9	18.4	19.2	17.2	17.5	18.0	18.8	16.4	16.7	17.2	18.0	15.5	15.7	16.2	17.0	14.6	14.8	15.4	16.2	
		S/T	1.00	0.84	0.71	0.56	1.00	0.85	0.71	0.57	1.00	0.87	0.74	0.60	1.00	1.00	0.76	0.62	1.00	1.00	0.78	0.64	1.00	1.00	0.83	0.69	
		ΔT	27	25	22	18	27	25	22	18	28	26	22	19	27	25	22	18	27	25	22	18	28	26	23	19	
	600	kW	0.75	0.75	0.75	0.76	0.84	0.84	0.84	0.84	0.93	0.93	0.93	0.94	1.03	1.03	1.03	1.04	1.15	1.15	1.15	1.15	1.28	1.28	1.28	1.29	
		Amps	3.3	3.2	3.2	3.3	3.6	3.6	3.6	3.7	4.1	4.1	4.1	4.1	4.5	4.5	4.5	4.6	5.1	5.1	5.1	5.1	5.7	5.7	5.7	5.7	
		Hi PR	188	189	190	194	218	219	220	223	249	249	251	254	282	283	284	287	317	318	320	323	356	356	358	361	
	675	Lo PR	129	131	134	139	137	138	142	147	144	145	148	154	149	151	154	160	155	157	160	165	162	164	167	172	
		MBh	18.2	18.4	18.9	19.7	18.0	18.3	18.8	19.6	17.6	17.8	18.3	19.1	16.8	17.0	17.5	18.3	15.8	16.1	16.6	17.4	14.9	15.2	15.7	16.5	
		S/T	1.00	0.88	0.75	0.60	1.00	0.89	0.75	0.61	1.00	1.00	0.78	0.63	1.00	1.00	0.80	0.65	1.00	1.00	0.82	0.68	1.00	1.00	1.00	0.73	
	85	520	ΔT	26	24	21	17	26	24	21	17	26	25	21	17	26	24	21	17	26	24	20	17	27	25	22	18
			kW	0.76	0.76	0.76	0.76	0.84	0.84	0.84	0.85	0.94	0.94	0.93	0.94	1.04	1.04	1.04	1.04	1.15	1.15	1.15	1.16	1.29	1.28	1.28	1.29
			Amps	3.3	3.3	3.3	3.3	3.7	3.7	3.6	3.7	4.1	4.1	4.1	4.1	4.6	4.6	4.6	4.6	5.1	5.1	5.1	5.1	5.7	5.7	5.7	5.7
600		Hi PR	190	191	192	196	220	220	222	225	250	251	253	256	284	284	286	289	319	320	321	325	357	358	360	363	
		Lo PR	132	133	137	142	140	141	144	150	146	148	151	156	152	154	157	162	158	159	162	168	165	166	169	175	
		MBh	18.6	18.8	19.4	20.2	18.4	18.7	19.2	20.0	18.0	18.2	18.7	19.5	17.2	17.4	18.0	18.8	16.2	16.5	17.0	17.8	15.3	15.6	16.1	16.9	
675		S/T	1.00	0.89	0.75	0.61	1.00	0.89	0.76	0.61	1.00	1.00	0.78	0.64	1.00	1.00	0.80	0.66	1.00	1.00	0.82	0.68	1.00	1.00	1.00	0.73	
		ΔT	25	23	20	16	25	23	20	16	25	24	20	16	25	23	20	16	25	23	20	16	26	24	21	17	
		kW	0.76	0.76	0.76	0.77	0.85	0.84	0.84	0.85	0.94	0.94	0.94	0.94	1.04	1.04	1.04	1.05	1.16	1.15	1.15	1.16	1.29	1.29	1.29	1.29	
85		520	Amps	3.3	3.3	3.3	3.3	3.7	3.7	3.7	3.7	4.1	4.1	4.1	4.1	4.6	4.6	4.6	4.6	5.1	5.1	5.1	5.1	5.7	5.7	5.7	5.7
			Hi PR	192	193	194	197	221	222	224	227	252	253	254	258	285	286	288	291	321	322	323	327	359	360	361	365
			Lo PR	135	136	139	145	142	144	147	153	149	151	154	159	155	156	160	165	160	162	165	171	167	169	172	178
600	MBh	18.1	18.4	18.9	19.7	18.0	18.2	18.7	19.5	17.5	17.8	18.3	19.1	16.7	17.0	17.5	18.3	15.8	16.0	16.5	17.3	14.9	15.1	15.7	16.5		
	S/T	1.00	0.94	0.81	0.67	1.00	1.00	0.81	0.67	1.00	1.00	0.84	0.70	1.00	1.00	0.86	0.72	1.00	1.00	0.78	0.64	1.00	1.00	1.00	0.79		
	ΔT	31	29	26	22	31	29	26	22	31	29	26	22	31	29	26	22	31	29	25	22	32	30	26	23		
675	kW	0.75	0.75	0.75	0.76	0.84	0.84	0.84	0.84	0.93	0.93	0.93	0.94	1.04	1.03	1.03	1.04	1.15	1.15	1.15	1.15	1.28	1.28	1.28	1.29		
	Amps	3.3	3.3	3.3	3.3	3.6	3.6	3.6	3.7	4.1	4.1	4.1	4.1	4.5	4.5	4.5	4.6	5.1	5.1	5.1	5.1	5.7	5.7	5.7	5.7		
	Hi PR	189	190	191	195	219	219	221	224	249	250	252	255	283	283	285	288	318	319	320	324	356	357	359	362		
85	600	Lo PR	131	133	136	141	139	140	144	149	146	147	150	156	151	153	156	161	157	158	162	167	164	165	169	174	
		MBh	18.5	18.7	19.2	20.0	18.3	18.6	19.1	19.9	17.9	18.1	18.6	19.4	17.1	17.3	17.8	18.6	16.1	16.4	16.9	17.7	15.2	15.5	16.0	16.8	
		S/T	1.00	0.98	0.85	0.70	1.00	1.00	0.85	0.71	1.00	1.00	0.88	0.74	1.00	1.00	1.00	0.76	1.00	1.00	0.78	0.64	1.00	1.00	1.00	0.83	
675	ΔT	30	28	24	21	30	28	24	21	30	28	25	21	30	28	24	21	30	28	24	21	31	29	25	22		
	kW	0.76	0.76	0.76	0.76	0.84	0.84	0.84	0.85	0.94	0.94	0.94	0.94	1.04	1.04	1.04	1.04	1.15	1.15	1.15	1.16	1.29	1.29	1.28	1.29		
	Amps	3.3	3.3	3.3	3.3	3.7	3.7	3.7	3.7	4.1	4.1	4.1	4.1	4.6	4.6	4.6	4.6	5.1	5.1	5.1	5.1	5.7	5.7	5.7	5.7		
85	675	Hi PR	191	192	193	196	221	221	223	226	251	252	253	257	284	285	287	290	320	321	322	326	358	359	360	364	
		Lo PR	134	135	138	144	141	143	146	152	148	150	153	158	154	155	159	164	159	161	164	170	166	168	171	177	
		MBh	18.9	19.1	19.6	20.4	18.7	19.0	19.5	20.3	18.3	18.5	19.0	19.8	17.5	17.7	18.2	19.0	16.5	16.8	17.3	18.1	15.6	15.9	16.4	17.2	
85	675	S/T	1.00	1.00	0.85	0.71	1.00	1.00	0.86	0.72	1.00	1.00	0.88	0.74	1.00	1.00	1.00	0.76	1.00	1.00	0.78	0.64	1.00	1.00	1.00	0.83	
		ΔT	29	27	24	20	29	27	23	20	29	27	24	20	29	27	23	20	29	27	23	20	30	28	24	21	
		kW	0.76	0.76	0.76	0.77	0.85	0.85	0.85	0.85	0.94	0.94	0.94	0.95	1.04	1.04	1.04	1.05	1.16	1.16	1.16	1.16	1.29	1.29	1.29	1.29	
85	675	Amps	3.3	3.3	3.3	3.3	3.7	3.7	3.7	3.7	4.1	4.1	4.1	4.1	4.6	4.6	4.6	4.6	5.1	5.1	5.1	5.1	5.7	5.7	5.7	5.7	
		Hi PR	193	194	195	198	222	223	224	228	253	254	255	259	286	287	288	292	322	323	324	327	360	361	362	366	
		Lo PR	137	138	141	147	144	146	149	154	151	153	156	161	157	158	161	167	162	164	167	173	169	171	174	180	

IDB: Entering Indoor Dry Bulb Temperature
 High and low pressures are measured at the liquid and suction service valves.
 Shaded area reflects AHRI (TVA) conditions
 kW = Total system power
 Amps = outdoor unit amps (compressor + fan)

IDB	AIRFLOW	OUTDOOR AMBIENT TEMPERATURE																							
		65°F				75°F				85°F				95°F				105°F				115°F			
		59	63	67	71	59	63	67	71	59	63	67	71	59	63	67	71	59	63	67	71	59	63	67	71
70	MBh	23.8	24.1	24.8	-	23.6	23.9	24.6	-	23.0	23.3	24.0	-	21.9	22.2	22.9	-	20.6	20.9	21.6	-	19.3	19.7	20.4	-
	S/T	0.58	0.50	0.35	-	0.59	0.51	0.36	-	1.00	0.54	0.39	-	1.00	0.56	0.41	-	1.00	0.58	0.43	-	1.00	1.00	0.49	-
	ΔT	20	18	15	-	20	18	15	-	20	18	15	-	20	18	15	-	20	18	15	-	21	19	16	-
	kW	1.30	1.30	1.29	-	1.45	1.45	1.45	-	1.63	1.63	1.63	-	1.82	1.82	1.81	-	2.03	2.03	2.02	-	2.28	2.27	2.27	-
	Amps	5.3	5.3	5.3	-	6.0	6.0	6.0	-	6.8	6.8	6.8	-	7.7	7.7	7.7	-	8.6	8.6	8.6	-	9.8	9.8	9.8	-
	Hi PR	237	238	240	-	275	276	278	-	315	316	317	-	357	358	360	-	403	404	406	-	452	453	455	-
Lo PR	129	131	134	-	137	139	142	-	144	146	149	-	150	152	155	-	156	158	161	-	163	165	168	-	
800	MBh	24.0	24.4	25.1	-	23.8	24.2	24.9	-	23.2	23.5	24.2	-	22.1	22.5	23.2	-	20.8	21.1	21.9	-	19.6	19.9	20.6	-
	S/T	0.67	0.59	0.44	-	0.68	0.59	0.44	-	1.00	0.62	0.47	-	1.00	0.64	0.49	-	1.00	0.67	0.52	-	1.00	1.00	0.57	-
	ΔT	19	17	14	-	19	17	14	-	19	17	14	-	19	17	14	-	18	17	13	-	20	18	15	-
	kW	1.31	1.31	1.30	-	1.46	1.46	1.46	-	1.64	1.64	1.63	-	1.83	1.82	1.82	-	2.04	2.04	2.03	-	2.28	2.28	2.28	-
	Amps	5.3	5.3	5.3	-	6.1	6.1	6.0	-	6.9	6.8	6.8	-	7.7	7.7	7.7	-	8.7	8.7	8.7	-	9.8	9.8	9.8	-
	Hi PR	239	240	242	-	277	278	280	-	316	318	319	-	359	360	362	-	405	406	408	-	454	455	457	-
Lo PR	131	133	136	-	139	140	144	-	146	147	151	-	152	153	157	-	158	159	162	-	165	166	170	-	
904	MBh	24.3	24.7	25.4	-	24.1	24.4	25.2	-	23.5	23.8	24.5	-	22.4	22.7	23.5	-	21.1	21.4	22.1	-	19.9	20.2	20.9	-
	S/T	0.73	0.64	0.50	-	0.73	0.65	0.50	-	1.00	0.68	0.53	-	1.00	0.70	0.55	-	1.00	0.72	0.58	-	1.00	1.00	0.63	-
	ΔT	18	16	13	-	18	16	13	-	18	16	13	-	18	16	13	-	17	16	12	-	19	17	14	-
	kW	1.31	1.31	1.31	-	1.47	1.47	1.47	-	1.65	1.64	1.64	-	1.83	1.83	1.83	-	2.04	2.04	2.04	-	2.29	2.29	2.29	-
	Amps	5.4	5.4	5.4	-	6.1	6.1	6.1	-	6.9	6.9	6.9	-	7.8	7.7	7.7	-	8.7	8.7	8.7	-	9.8	9.8	9.8	-
	Hi PR	241	242	244	-	279	280	282	-	318	319	321	-	361	362	364	-	407	408	409	-	456	457	458	-
Lo PR	133	134	138	-	141	142	146	-	148	149	153	-	154	155	158	-	159	161	164	-	167	168	171	-	

IDB	AIRFLOW	OUTDOOR AMBIENT TEMPERATURE																							
		65°F				75°F				85°F				95°F				105°F				115°F			
		59	63	67	71	59	63	67	71	59	63	67	71	59	63	67	71	59	63	67	71	59	63	67	71
700	MBh	23.8	24.1	24.9	26.0	23.6	23.9	24.6	25.7	23.0	23.3	24.0	25.1	21.9	22.2	22.9	24.0	20.6	20.9	21.6	22.7	19.4	19.7	20.4	21.5
	S/T	0.73	0.64	0.49	0.34	1.00	0.65	0.50	0.34	1.00	0.68	0.53	0.37	1.00	0.70	0.55	0.39	1.00	1.00	0.57	0.42	1.00	1.00	0.63	0.47
	ΔT	24	22	19	15	24	22	19	15	24	22	19	16	24	22	19	15	23	22	18	15	24	23	19	16
	kW	1.30	1.30	1.29	1.31	1.45	1.45	1.45	1.46	1.63	1.63	1.62	1.64	1.82	1.82	1.81	1.82	2.03	2.03	2.02	2.04	2.27	2.27	2.27	2.28
	Amps	5.3	5.3	5.3	5.3	6.0	6.0	6.0	6.0	6.8	6.8	6.8	6.8	7.7	7.7	7.7	7.7	8.6	8.6	8.6	8.7	9.8	9.8	9.7	9.8
	Hi PR	237	239	240	244	275	276	278	282	315	316	317	322	357	358	360	364	403	404	406	410	452	453	455	459
Lo PR	129	131	134	140	137	139	142	148	144	146	149	155	150	152	155	161	156	158	161	166	163	165	168	174	
800	MBh	24.0	24.4	25.1	26.2	23.8	24.2	24.9	26.0	23.2	23.5	24.3	25.4	22.1	22.5	23.2	24.3	20.8	21.1	21.9	23.0	19.6	19.9	20.7	21.8
	S/T	0.81	0.73	0.58	0.42	1.00	0.73	0.59	0.43	1.00	0.76	0.61	0.46	1.00	0.78	0.63	0.48	1.00	1.00	0.66	0.50	1.00	1.00	0.71	0.56
	ΔT	23	21	18	14	23	21	18	14	23	21	18	14	22	21	17	14	22	21	17	14	23	22	18	15
	kW	1.31	1.31	1.30	1.31	1.46	1.46	1.46	1.47	1.64	1.64	1.63	1.64	1.83	1.82	1.82	1.83	2.04	2.03	2.03	2.04	2.28	2.28	2.28	2.29
	Amps	5.3	5.3	5.3	5.4	6.1	6.0	6.0	6.1	6.8	6.8	6.8	6.9	7.7	7.7	7.7	7.7	8.7	8.7	8.7	8.7	9.8	9.8	9.8	9.8
	Hi PR	239	240	242	246	277	278	280	284	317	318	319	324	359	360	362	366	405	406	408	412	454	455	457	461
Lo PR	131	133	136	141	139	141	144	149	146	147	151	156	152	153	157	162	158	159	162	168	165	166	170	175	
904	MBh	24.3	24.7	25.4	26.5	24.1	24.5	25.2	26.3	23.5	23.8	24.6	25.6	22.4	22.8	23.5	24.6	21.1	21.4	22.2	23.3	19.9	20.2	21.0	22.0
	S/T	0.87	0.79	0.64	0.48	1.00	0.79	0.64	0.49	1.00	0.82	0.67	0.52	1.00	1.00	0.69	0.54	1.00	1.00	0.72	0.56	1.00	1.00	0.77	0.62
	ΔT	22	20	17	13	22	20	17	13	22	20	17	13	22	20	17	13	21	20	16	13	22	21	17	14
	kW	1.31	1.31	1.31	1.32	1.47	1.47	1.47	1.48	1.64	1.64	1.64	1.65	1.83	1.83	1.83	1.84	2.04	2.04	2.04	2.05	2.29	2.29	2.29	2.30
	Amps	5.4	5.4	5.4	5.4	6.1	6.1	6.1	6.1	6.9	6.9	6.9	6.9	7.7	7.7	7.7	7.8	8.7	8.7	8.7	8.7	9.8	9.8	9.8	9.9
	Hi PR	241	242	244	248	279	280	282	286	319	320	321	325	361	362	364	368	407	408	410	414	456	457	459	463
Lo PR	133	134	138	143	141	142	146	151	148	149	153	158	154	155	158	164	159	161	164	170	167	168	172	177	

IDB: Entering Indoor Dry Bulb Temperature
 High and low pressures are measured at the liquid and suction service valves.
 Shaded area reflects ACCA (TVA) conditions
 kW = Total system power
 Amps = outdoor unit amps (compressor + fan)

EXPANDED COOLING DATA — GSZC160241C* / CA*F3137*6A*+MBVC1200**-.1A*+TX — HIGH STAGE

IDB		OUTDOOR AMBIENT TEMPERATURE												115°F																	
		65°F						75°F						85°F						95°F						105°F					
		59	63	67	71	75	79	59	63	67	71	75	79	59	63	67	71	75	79	59	63	67	71	75	79	59	63	67	71	75	79
		ENTERING INDOOR WET BULB TEMPERATURE																													
		AIRFLOW																													
80	700	MBh	23.9	24.3	25.0	26.1	23.7	24.1	24.8	25.9	23.1	23.4	24.1	25.2	22.0	22.3	23.1	24.2	20.7	21.0	21.7	22.8	19.5	19.8	20.5	21.6					
		S/T	1.00	0.78	0.63	0.47	1.00	0.79	0.64	0.48	1.00	1.00	0.67	0.51	1.00	1.00	0.69	0.53	1.00	1.00	0.71	0.55	1.00	1.00	1.00	0.61					
		ΔT	28	26	23	19	27	26	22	19	28	26	23	19	27	26	22	19	27	25	22	19	28	27	23	20					
		kW	1.30	1.30	1.29	1.31	1.45	1.45	1.45	1.46	1.63	1.63	1.62	1.64	1.82	1.82	1.81	1.83	2.03	2.03	2.02	2.04	2.28	2.27	2.27	2.28					
		Amps	5.3	5.3	5.3	5.3	6.0	6.0	6.0	6.1	6.8	6.8	6.8	6.9	7.7	7.7	7.7	7.7	8.6	8.6	8.6	8.7	9.8	9.8	9.8	9.8					
	800	Hi PR	238	239	241	245	276	277	278	283	315	316	318	322	358	359	360	365	404	405	406	410	453	454	455	459					
		Lo PR	130	132	135	140	138	139	143	148	145	146	150	155	151	152	156	161	156	158	161	167	164	165	169	174					
		MBh	24.2	24.5	25.2	26.3	24.0	24.3	25.0	26.1	23.3	23.7	24.4	25.5	22.3	22.6	23.3	24.4	20.9	21.3	22.0	23.1	19.7	20.1	20.8	21.9					
		S/T	1.00	0.86	0.72	0.56	1.00	0.87	0.72	0.57	1.00	1.00	0.75	0.59	1.00	1.00	0.77	0.61	1.00	1.00	0.80	0.64	1.00	1.00	1.00	0.70					
		ΔT	26	25	21	18	26	25	21	18	27	25	22	18	26	25	21	18	26	24	21	18	27	25	22	19					
904	kW	1.31	1.31	1.30	1.32	1.46	1.46	1.46	1.47	1.64	1.64	1.63	1.65	1.83	1.82	1.82	1.83	2.04	2.04	2.03	2.04	2.28	2.28	2.28	2.29						
	Amps	5.3	5.3	5.3	5.4	6.1	6.1	6.0	6.1	6.9	6.8	6.8	6.9	7.7	7.7	7.7	7.8	8.7	8.7	8.7	8.7	9.8	9.8	9.8	9.8						
	Hi PR	240	241	243	247	278	279	280	284	317	318	320	324	360	361	362	367	406	407	408	412	455	456	457	461						
	Lo PR	132	133	136	142	139	141	144	150	146	148	151	157	152	154	157	163	158	160	163	169	165	167	170	176						
	MBh	24.5	24.8	25.5	26.6	24.2	24.6	25.3	26.4	23.6	24.0	24.7	25.8	22.5	22.9	23.6	24.7	21.2	21.6	22.3	23.4	20.0	20.4	21.1	22.2						
85	700	S/T	1.00	0.92	0.77	0.62	1.00	0.93	0.78	0.63	1.00	1.00	0.81	0.65	1.00	1.00	0.83	0.67	1.00	1.00	0.85	0.70	1.00	1.00	1.00	0.75					
		ΔT	25	24	20	17	25	24	20	17	26	24	21	17	25	24	20	17	25	23	20	17	26	24	21	18					
		kW	1.31	1.31	1.31	1.32	1.47	1.47	1.47	1.48	1.64	1.64	1.64	1.65	1.83	1.83	1.83	1.84	2.04	2.04	2.04	2.05	2.29	2.29	2.29	2.30					
		Amps	5.4	5.4	5.4	5.4	6.1	6.1	6.1	6.1	6.9	6.9	6.9	6.9	7.7	7.7	7.7	7.8	8.7	8.7	8.7	8.8	9.8	9.8	9.8	9.9					
		Hi PR	242	243	244	249	279	281	282	286	319	320	322	326	362	363	364	368	407	408	410	414	456	457	459	463					
	800	Lo PR	133	133	137	142	140	141	145	150	148	150	153	159	154	156	159	165	160	162	165	170	167	169	172	178					
		MBh	24.3	24.7	25.4	26.5	24.1	24.5	25.2	26.3	23.5	23.8	24.5	25.6	22.4	22.8	23.5	24.6	21.1	21.4	22.2	23.2	19.9	20.2	20.9	22.0					
		S/T	1.00	0.89	0.74	0.59	1.00	1.00	0.75	0.59	1.00	1.00	0.78	0.62	1.00	1.00	0.80	0.64	1.00	1.00	1.00	0.66	1.00	1.00	1.00	0.72					
		ΔT	31	29	26	23	31	29	26	23	31	29	26	23	31	29	26	23	31	29	26	22	32	30	27	23					
		kW	1.30	1.30	1.30	1.31	1.46	1.46	1.45	1.47	1.63	1.63	1.63	1.64	1.82	1.82	1.82	1.83	2.03	2.03	2.03	2.04	2.28	2.28	2.27	2.29					
904	Amps	5.3	5.3	5.3	5.4	6.0	6.0	6.0	6.1	6.8	6.8	6.8	6.9	7.7	7.7	7.7	7.7	8.7	8.6	8.6	8.7	9.8	9.8	9.8	9.8						
	Hi PR	239	240	242	246	277	278	279	284	316	317	319	323	359	360	362	366	405	406	407	412	454	455	456	461						
	Lo PR	132	133	137	142	140	141	145	150	147	148	152	157	153	154	158	163	158	160	163	169	166	167	171	176						
	MBh	24.6	24.9	25.6	26.7	24.4	24.7	25.4	26.5	23.7	24.1	24.8	25.9	22.7	23.0	23.7	24.8	21.3	21.7	22.4	23.5	20.1	20.5	21.2	22.3						
	S/T	1.00	0.97	0.83	0.67	1.00	1.00	0.83	0.68	1.00	1.00	0.86	0.70	1.00	1.00	1.00	0.73	1.00	1.00	1.00	0.75	1.00	1.00	1.00	0.81						
85	ΔT	30	28	25	21	30	28	25	21	30	28	25	22	30	28	25	21	30	28	25	21	31	29	26	22						
	kW	1.31	1.31	1.31	1.32	1.47	1.46	1.46	1.47	1.64	1.64	1.64	1.65	1.83	1.83	1.83	1.84	2.04	2.04	2.04	2.05	2.29	2.29	2.28	2.29						
	Amps	5.4	5.3	5.3	5.4	6.1	6.1	6.1	6.1	6.9	6.9	6.8	6.9	7.7	7.7	7.7	7.8	8.7	8.7	8.7	8.7	9.8	9.8	9.8	9.9						
	Hi PR	241	242	244	248	279	280	281	286	318	319	321	325	361	362	364	368	407	408	409	414	456	457	458	463						
	Lo PR	133	135	138	144	141	143	146	152	148	150	153	159	154	156	159	165	160	162	165	171	167	169	172	178						
85	MBh	24.9	25.2	25.9	27.0	24.7	25.0	25.7	26.8	24.0	24.4	25.1	26.2	22.9	23.3	24.0	25.1	21.6	22.0	22.7	23.8	20.4	20.8	21.5	22.6						
	S/T	1.00	1.00	0.89	0.73	1.00	1.00	0.89	0.74	1.00	1.00	0.92	0.76	1.00	1.00	1.00	0.78	1.00	1.00	1.00	0.81	1.00	1.00	1.00	0.87						
	ΔT	29	27	24	21	29	27	24	20	29	27	24	21	29	27	24	20	29	27	24	20	30	28	25	21						
	kW	1.32	1.32	1.31	1.33	1.47	1.47	1.47	1.48	1.65	1.65	1.64	1.66	1.84	1.84	1.83	1.84	2.05	2.05	2.04	2.06	2.29	2.29	2.29	2.30						
	Amps	5.4	5.4	5.4	5.4	6.1	6.1	6.1	6.1	6.9	6.9	6.9	6.9	7.8	7.8	7.7	7.8	8.7	8.7	8.7	8.8	9.9	9.9	9.8	9.9						
Lo PR	243	244	246	250	281	282	283	287	320	321	323	327	363	364	365	370	409	410	411	415	458	459	460	464							
Lo PR	135	137	140	146	143	145	148	154	150	152	155	161	156	158	161	167	162	163	167	172	169	171	174	180							

IDB: Entering Indoor Dry Bulb Temperature
 High and low pressures are measured at the liquid and suction service valves.
 Shaded area reflects AHRI (TVA) conditions
 kW = Total system power
 Amps = outdoor unit amps (compressor + fan)

IDB		OUTDOOR AMBIENT TEMPERATURE																							
		65°F				75°F				85°F				95°F				105°F				115°F			
		59	63	67	71	59	63	67	71	59	63	67	71	59	63	67	71	59	63	67	71	59	63	67	71
70	AIRFLOW	59	63	67	71	59	63	67	71	59	63	67	71	59	63	67	71	59	63	67	71	59	63	67	71
	MBh	26.5	26.9	27.7	-	26.3	26.6	27.4	-	25.6	26.0	26.7	-	24.4	24.8	25.6	-	22.9	23.3	24.1	-	21.6	22.0	22.8	-
	S/T	0.59	0.51	0.39	-	0.59	0.52	0.39	-	0.62	0.54	0.42	-	0.64	0.56	0.43	-	1.00	0.58	0.46	-	1.00	0.63	0.50	-
	ΔT	20	19	15	-	20	19	15	-	21	19	15	-	20	19	15	-	20	18	15	-	21	19	16	-
	kW	1.09	1.09	1.08	-	1.22	1.22	1.21	-	1.36	1.36	1.36	-	1.52	1.52	1.52	-	1.70	1.70	1.69	-	1.90	1.90	1.90	-
	Amps	4.5	4.5	4.5	-	5.1	5.1	5.1	-	5.8	5.8	5.8	-	6.5	6.5	6.5	-	7.3	7.3	7.3	-	8.3	8.3	8.3	-
	Hi PR	193	194	196	-	224	225	226	-	256	257	258	-	290	291	292	-	327	328	329	-	367	368	369	-
	Lo PR	123	124	127	-	130	132	135	-	137	138	141	-	142	144	147	-	148	149	152	-	154	156	159	-
	MBh	26.8	27.2	28.0	-	26.6	26.9	27.7	-	25.9	26.2	27.0	-	24.7	25.1	25.8	-	23.2	23.6	24.4	-	21.9	22.3	23.1	-
	S/T	0.63	0.56	0.43	-	0.64	0.57	0.44	-	0.66	0.59	0.46	-	1.00	0.61	0.48	-	1.00	0.63	0.50	-	1.00	0.68	0.55	-
ΔT	20	18	14	-	20	18	14	-	20	18	14	-	19	18	14	-	19	17	14	-	20	19	15	-	
kW	1.09	1.09	1.09	-	1.22	1.22	1.22	-	1.37	1.37	1.37	-	1.53	1.53	1.52	-	1.70	1.70	1.70	-	1.91	1.91	1.91	-	
Amps	4.6	4.5	4.5	-	5.2	5.1	5.1	-	5.8	5.8	5.8	-	6.5	6.5	6.5	-	7.3	7.3	7.3	-	8.3	8.3	8.3	-	
Hi PR	195	196	197	-	225	226	227	-	257	258	259	-	291	292	294	-	329	329	331	-	368	369	370	-	
Lo PR	124	126	129	-	132	133	136	-	138	140	143	-	144	145	148	-	149	151	154	-	156	157	160	-	
MBh	27.3	27.7	28.5	-	27.1	27.5	28.3	-	26.4	26.8	27.6	-	25.2	25.6	26.4	-	23.8	24.1	24.9	-	22.4	22.8	23.6	-	
S/T	0.67	0.60	0.47	-	0.67	0.60	0.47	-	0.70	0.63	0.50	-	1.00	0.64	0.52	-	1.00	0.66	0.54	-	1.00	0.71	0.59	-	
ΔT	18	16	13	-	18	16	13	-	19	17	13	-	18	16	13	-	18	16	13	-	19	17	14	-	
kW	1.10	1.10	1.10	-	1.23	1.23	1.23	-	1.38	1.37	1.37	-	1.53	1.53	1.53	-	1.71	1.71	1.71	-	1.92	1.92	1.91	-	
Amps	4.6	4.6	4.6	-	5.2	5.2	5.2	-	5.8	5.8	5.8	-	6.6	6.6	6.6	-	7.4	7.4	7.4	-	8.3	8.3	8.3	-	
Hi PR	197	198	199	-	227	228	229	-	259	260	261	-	293	294	296	-	330	331	333	-	370	371	372	-	
Lo PR	127	128	131	-	134	136	139	-	141	142	145	-	146	148	151	-	152	153	156	-	158	160	163	-	

IDB		OUTDOOR AMBIENT TEMPERATURE																							
		65°F				75°F				85°F				95°F				105°F				115°F			
		59	63	67	71	59	63	67	71	59	63	67	71	59	63	67	71	59	63	67	71	59	63	67	71
75	AIRFLOW	59	63	67	71	59	63	67	71	59	63	67	71	59	63	67	71	59	63	67	71	59	63	67	71
	MBh	26.5	26.9	27.7	28.9	26.3	26.7	27.5	28.7	25.6	26.0	26.8	28.0	24.4	24.8	25.6	26.8	23.0	23.3	24.1	25.3	21.6	22.0	22.8	24.0
	S/T	0.71	0.64	0.51	0.37	0.72	0.64	0.51	0.38	1.00	0.67	0.54	0.40	1.00	0.69	0.56	0.42	1.00	0.71	0.58	0.44	1.00	1.00	0.63	0.49
	ΔT	25	23	19	16	25	23	19	15	25	23	19	16	25	23	19	15	24	22	19	15	26	24	20	16
	kW	1.09	1.09	1.08	1.09	1.22	1.22	1.21	1.22	1.36	1.36	1.36	1.37	1.52	1.52	1.52	1.53	1.70	1.70	1.69	1.70	1.90	1.90	1.90	1.91
	Amps	4.5	4.5	4.5	4.6	5.1	5.1	5.1	5.2	5.8	5.8	5.8	5.8	6.5	6.5	6.5	6.5	7.3	7.3	7.3	7.3	8.3	8.3	8.2	8.3
	Hi PR	194	194	196	199	224	225	226	230	256	257	258	261	290	291	292	296	327	328	330	333	367	368	369	372
	Lo PR	123	124	127	133	130	132	135	140	137	138	141	146	142	144	147	152	148	149	152	157	154	156	159	164
	MBh	26.8	27.2	28.0	29.2	26.6	27.0	27.7	28.9	25.9	26.3	27.1	28.3	24.7	25.1	25.9	27.1	23.2	23.6	24.4	25.6	21.9	22.3	23.1	24.3
	S/T	0.75	0.68	0.55	0.42	0.76	0.69	0.56	0.42	1.00	0.71	0.58	0.45	1.00	0.73	0.60	0.47	1.00	0.75	0.62	0.49	1.00	1.00	0.67	0.54
ΔT	24	22	18	15	24	22	18	15	24	22	18	15	24	22	18	15	23	22	18	14	25	23	19	15	
kW	1.09	1.09	1.09	1.10	1.22	1.22	1.22	1.23	1.37	1.37	1.37	1.37	1.53	1.52	1.52	1.53	1.70	1.70	1.70	1.71	1.91	1.91	1.91	1.92	
Amps	4.5	4.5	4.5	4.6	5.1	5.1	5.1	5.2	5.8	5.8	5.8	5.8	6.5	6.5	6.5	6.6	7.3	7.3	7.3	7.4	8.3	8.3	8.3	8.3	
Hi PR	195	196	197	200	225	226	228	231	257	258	259	263	292	292	294	297	329	330	331	334	368	369	370	374	
Lo PR	124	126	129	134	132	133	136	141	138	140	143	148	144	145	148	153	149	151	154	159	156	157	160	166	
MBh	27.3	27.7	28.5	29.7	27.1	27.5	28.3	29.5	26.4	26.8	27.6	28.8	25.2	25.6	26.4	27.6	23.8	24.1	24.9	26.1	22.4	22.8	23.6	24.8	
S/T	0.79	0.72	0.59	0.45	1.00	0.72	0.60	0.46	1.00	0.75	0.62	0.48	1.00	0.77	0.64	0.50	1.00	0.79	0.66	0.52	1.00	1.00	0.71	0.57	
ΔT	23	21	17	13	23	21	17	13	23	21	17	14	23	21	17	13	22	20	17	13	23	22	18	14	
kW	1.10	1.10	1.10	1.11	1.23	1.23	1.23	1.24	1.38	1.37	1.37	1.38	1.53	1.53	1.53	1.54	1.71	1.71	1.71	1.72	1.92	1.91	1.91	1.92	
Amps	4.6	4.6	4.6	4.6	5.2	5.2	5.2	5.2	5.8	5.8	5.8	5.9	6.6	6.6	6.6	6.6	7.4	7.4	7.4	7.4	8.3	8.3	8.3	8.4	
Hi PR	197	198	199	202	227	228	230	233	259	260	261	265	294	294	296	299	331	331	333	336	370	371	372	376	
Lo PR	127	128	131	136	134	136	139	144	141	142	145	150	146	148	151	156	152	153	156	161	158	160	163	168	

IDB: Entering Indoor Dry Bulb Temperature
 High and low pressures are measured at the liquid and suction service valves.
 Shaded area reflects ACCA (TVA) conditions
 kW = Total system power
 Amps = outdoor unit amps (compressor + fan)

IDB	AIRFLOW	OUTDOOR AMBIENT TEMPERATURE												ENTERING INDOOR WET BULB TEMPERATURE											
		65°F				75°F				85°F				95°F				105°F				115°F			
		59	63	67	71	59	63	67	71	59	63	67	71	59	63	67	71	59	63	67	71	59	63	67	71
700	MBh	26.7	27.0	27.8	29.0	26.4	26.8	27.6	28.8	25.7	26.1	26.9	28.1	24.5	24.9	25.7	26.9	23.1	23.5	24.3	25.5	21.8	22.1	22.9	24.1
	S/T	1.00	0.76	0.63	0.49	1.00	0.76	0.63	0.50	1.00	0.79	0.66	0.52	1.00	0.80	0.68	0.54	1.00	1.00	0.70	0.56	1.00	1.00	0.75	0.61
	ΔT	29	27	23	20	29	27	23	20	29	27	24	20	29	27	23	20	29	27	23	19	30	28	24	21
	kW	1.09	1.09	1.08	1.09	1.22	1.22	1.21	1.22	1.36	1.36	1.36	1.37	1.52	1.52	1.52	1.53	1.70	1.70	1.70	1.69	1.90	1.90	1.90	1.91
	Amps	4.5	4.5	4.5	4.6	5.1	5.1	5.1	5.2	5.8	5.8	5.8	5.8	6.5	6.5	6.5	6.5	7.3	7.3	7.3	7.4	8.3	8.3	8.3	8.3
	Hi PR	194	195	196	199	224	225	227	230	256	257	258	262	291	291	293	296	328	329	330	333	367	368	369	373
	Lo PR	123	125	128	133	131	132	135	141	137	139	142	147	143	144	147	153	148	150	153	158	155	156	160	165
780	MBh	27.0	27.3	28.1	29.3	26.7	27.1	27.9	29.1	26.0	26.4	27.2	28.4	24.8	25.2	26.0	27.2	23.4	23.8	24.5	25.8	22.1	22.4	23.2	24.4
	S/T	1.00	0.80	0.67	0.54	1.00	0.81	0.68	0.54	1.00	0.83	0.70	0.57	1.00	1.00	0.72	0.58	1.00	1.00	0.74	0.61	1.00	1.00	0.79	0.65
	ΔT	28	26	23	19	28	26	22	19	28	26	23	19	28	26	22	19	28	26	22	18	29	27	23	20
	kW	1.09	1.09	1.09	1.10	1.22	1.22	1.22	1.23	1.37	1.37	1.37	1.38	1.53	1.53	1.53	1.53	1.70	1.70	1.70	1.71	1.91	1.91	1.91	1.92
	Amps	4.6	4.5	4.5	4.6	5.1	5.1	5.1	5.2	5.8	5.8	5.8	5.8	6.5	6.5	6.5	6.6	7.3	7.3	7.3	7.4	8.3	8.3	8.3	8.3
	Hi PR	195	196	197	201	226	227	228	231	258	258	260	263	292	293	294	298	329	330	331	335	369	369	371	374
	Lo PR	125	126	129	135	132	134	137	142	139	140	143	149	144	146	149	154	150	151	154	159	156	158	161	166
900	MBh	27.5	27.9	28.6	29.8	27.2	27.6	28.4	29.6	26.5	26.9	27.7	28.9	25.4	25.7	26.5	27.7	23.9	24.3	25.1	26.3	22.6	23.0	23.7	25.0
	S/T	1.00	0.84	0.71	0.57	1.00	0.84	0.71	0.58	1.00	0.87	0.74	0.60	1.00	1.00	0.76	0.62	1.00	1.00	0.78	0.64	1.00	1.00	0.83	0.69
	ΔT	27	25	21	18	27	25	21	18	27	25	22	18	27	25	21	18	27	25	21	17	28	26	22	19
	kW	1.10	1.10	1.10	1.11	1.23	1.23	1.23	1.24	1.38	1.37	1.37	1.38	1.53	1.53	1.53	1.54	1.71	1.71	1.71	1.72	1.92	1.92	1.91	1.92
	Amps	4.6	4.6	4.6	4.6	5.2	5.2	5.2	5.2	5.8	5.8	5.8	5.9	6.6	6.6	6.6	6.6	7.4	7.4	7.4	7.4	8.3	8.3	8.3	8.4
	Hi PR	197	198	199	203	228	229	230	233	260	260	262	265	294	295	296	300	331	332	333	337	371	371	373	376
	Lo PR	127	129	132	137	135	136	139	144	141	143	146	151	147	148	151	157	152	154	157	162	159	160	163	169
85	MBh	27.1	27.5	28.3	29.5	26.9	27.2	28.0	29.2	26.2	26.6	27.3	28.6	25.0	25.4	26.2	27.4	23.5	23.9	24.7	25.9	22.2	22.6	23.4	24.6
	S/T	1.00	0.85	0.72	0.59	1.00	0.86	0.73	0.59	1.00	1.00	0.75	0.62	1.00	1.00	0.77	0.64	1.00	1.00	0.79	0.66	1.00	1.00	1.00	0.71
	ΔT	33	31	27	24	33	31	27	23	33	31	27	24	33	31	27	23	32	30	27	23	34	32	28	24
	kW	1.09	1.09	1.09	1.10	1.22	1.22	1.22	1.23	1.37	1.36	1.36	1.37	1.52	1.52	1.52	1.53	1.70	1.70	1.70	1.71	1.91	1.91	1.90	1.91
	Amps	4.5	4.5	4.5	4.6	5.1	5.1	5.1	5.2	5.8	5.8	5.8	5.8	6.5	6.5	6.5	6.6	7.3	7.3	7.3	7.4	8.3	8.3	8.3	8.3
	Hi PR	195	196	197	200	225	226	227	231	257	258	259	263	292	292	294	297	329	329	329	331	368	369	370	374
	Lo PR	125	127	130	135	132	134	137	142	139	141	144	149	145	146	149	154	150	151	155	160	157	158	161	167
780	MBh	27.4	27.8	28.6	29.8	27.2	27.5	28.3	29.5	26.5	26.8	27.6	28.8	25.3	25.7	26.4	27.7	23.8	24.2	25.0	26.2	22.5	22.9	23.7	24.9
	S/T	1.00	0.90	0.77	0.63	1.00	1.00	0.77	0.64	1.00	1.00	0.80	0.66	1.00	1.00	0.82	0.68	1.00	1.00	0.84	0.70	1.00	1.00	1.00	0.75
	ΔT	32	30	26	23	32	30	26	23	32	30	27	23	32	30	26	23	31	30	26	22	33	31	27	23
	kW	1.10	1.09	1.09	1.10	1.23	1.22	1.22	1.23	1.37	1.37	1.37	1.38	1.53	1.53	1.53	1.54	1.71	1.70	1.70	1.71	1.91	1.91	1.91	1.92
	Amps	4.6	4.6	4.5	4.6	5.2	5.2	5.1	5.2	5.8	5.8	5.8	5.9	6.5	6.5	6.5	6.6	7.4	7.4	7.3	7.4	8.3	8.3	8.3	8.3
	Hi PR	196	197	198	202	227	227	229	232	259	259	261	264	293	294	295	298	330	331	332	336	370	370	372	375
	Lo PR	127	128	131	136	134	135	139	144	141	142	145	150	146	148	151	156	151	153	156	161	158	160	163	168
900	MBh	27.9	28.3	29.1	30.3	27.7	28.1	28.8	30.1	27.0	27.4	28.2	29.4	25.8	26.2	27.0	28.2	24.4	24.7	25.5	26.7	23.0	23.4	24.2	25.4
	S/T	1.00	0.93	0.80	0.67	1.00	1.00	0.81	0.67	1.00	1.00	0.83	0.70	1.00	1.00	0.85	0.72	1.00	1.00	1.00	0.74	1.00	1.00	1.00	0.79
	ΔT	31	29	25	21	31	29	25	21	31	29	25	22	31	29	25	21	30	28	25	21	31	30	26	22
	kW	1.10	1.10	1.10	1.11	1.23	1.23	1.23	1.24	1.38	1.38	1.38	1.39	1.54	1.54	1.53	1.54	1.71	1.71	1.71	1.72	1.92	1.92	1.92	1.93
	Amps	4.6	4.6	4.6	4.6	5.2	5.2	5.2	5.2	5.9	5.9	5.8	5.9	6.6	6.6	6.6	6.6	7.4	7.4	7.4	7.4	8.3	8.3	8.3	8.4
	Hi PR	198	199	200	204	229	229	231	234	260	261	263	266	295	296	297	300	332	333	334	337	371	372	374	377
	Lo PR	129	131	134	139	136	138	141	146	143	145	148	153	149	150	153	158	154	155	159	164	161	162	165	171

IDB: Entering Indoor Dry Bulb Temperature
 High and low pressures are measured at the liquid and suction service valves.
 Shaded area reflects AHRI (TVA) conditions
 kW = Total system power
 Amps = outdoor unit amps (compressor + fan)

IDB	AIRFLOW	OUTDOOR AMBIENT TEMPERATURE												ENTERING INDOOR WET BULB TEMPERATURE											
		65°F				75°F				85°F				95°F				105°F				115°F			
		59	63	67	71	59	63	67	71	59	63	67	71	59	63	67	71	59	63	67	71	59	63	67	71
70	MBh	35.5	36.0	37.0	-	35.1	35.6	36.7	-	34.2	34.7	35.8	-	32.7	33.2	34.2	-	30.7	31.2	32.3	-	29.0	29.5	30.5	-
	S/T	0.66	0.59	0.45	-	0.67	0.60	0.46	-	0.70	0.62	0.48	-	0.72	0.64	0.50	-	1.00	0.66	0.53	-	1.00	0.71	0.58	-
	ΔT	19	17	14	-	19	17	13	-	19	17	14	-	19	17	13	-	19	17	13	-	20	18	14	-
	kW	1.89	1.89	1.89	-	2.13	2.12	2.12	-	2.39	2.39	2.38	-	2.67	2.67	2.67	-	2.99	2.99	2.99	-	3.36	3.36	3.36	-
	Amps	7.6	7.6	7.6	-	8.7	8.7	8.7	-	9.9	9.9	9.9	-	11.2	11.2	11.2	-	12.6	12.6	12.6	-	14.3	14.3	14.3	-
	Hi/PR	251	252	254	-	291	292	293	-	332	333	335	-	376	377	379	-	424	425	427	-	475	476	478	-
Lo/PR	121	123	126	-	128	130	133	-	135	136	139	-	140	142	145	-	145	147	150	-	152	153	156	-	
1200	MBh	35.9	36.4	37.5	-	35.6	36.1	37.2	-	34.7	35.2	36.3	-	33.1	33.6	34.7	-	31.2	31.7	32.8	-	29.5	30.0	31.0	-
	S/T	0.70	0.62	0.48	-	0.70	0.63	0.49	-	0.73	0.65	0.52	-	0.75	0.67	0.54	-	1.00	0.69	0.56	-	1.00	0.74	0.61	-
	ΔT	18	16	13	-	18	16	13	-	18	16	13	-	18	16	13	-	18	16	12	-	19	17	14	-
	kW	1.90	1.90	1.89	-	2.14	2.13	2.13	-	2.40	2.40	2.39	-	2.68	2.68	2.68	-	3.00	3.00	2.99	-	3.37	3.37	3.37	-
	Amps	7.6	7.6	7.6	-	8.7	8.7	8.7	-	9.9	9.9	9.9	-	11.2	11.2	11.2	-	12.7	12.7	12.7	-	14.4	14.4	14.4	-
	Hi/PR	253	254	256	-	292	293	295	-	334	335	336	-	378	379	381	-	426	427	429	-	477	478	480	-
Lo/PR	123	124	127	-	130	132	135	-	136	138	141	-	142	143	146	-	147	149	152	-	154	155	158	-	
1350	MBh	36.7	37.2	38.2	-	36.4	36.9	37.9	-	35.4	35.9	37.0	-	33.9	34.4	35.4	-	32.0	32.4	33.5	-	30.2	30.7	31.7	-
	S/T	0.71	0.63	0.50	-	0.72	0.64	0.50	-	0.74	0.67	0.53	-	1.00	0.68	0.55	-	1.00	0.71	0.57	-	1.00	0.76	0.62	-
	ΔT	17	15	12	-	17	15	12	-	17	15	12	-	17	15	12	-	17	15	11	-	18	16	13	-
	kW	1.91	1.91	1.90	-	2.15	2.14	2.14	-	2.41	2.41	2.40	-	2.69	2.69	2.69	-	3.01	3.01	3.00	-	3.38	3.38	3.38	-
	Amps	7.7	7.7	7.7	-	8.8	8.8	8.7	-	10.0	10.0	9.9	-	11.3	11.3	11.2	-	12.7	12.7	12.7	-	14.4	14.4	14.4	-
	Hi/PR	255	256	258	-	295	296	298	-	336	337	339	-	380	381	383	-	428	429	431	-	479	480	482	-
Lo/PR	125	127	130	-	133	134	137	-	139	140	143	-	144	146	149	-	150	151	154	-	156	158	161	-	

75	MBh	35.5	36.0	37.0	38.6	35.2	35.7	36.7	38.3	34.3	34.7	35.8	37.4	32.7	33.2	34.2	35.8	30.8	31.3	32.3	33.9	29.0	29.5	30.5	32.1
	S/T	0.79	0.72	0.58	0.44	0.80	0.72	0.59	0.45	1.00	0.75	0.61	0.47	1.00	0.77	0.63	0.49	1.00	0.79	0.66	0.51	1.00	0.84	0.71	0.56
	ΔT	23	21	18	14	23	21	18	14	23	21	18	14	23	21	18	14	23	21	17	14	24	22	18	15
	kW	1.89	1.89	1.88	1.90	2.13	2.12	2.12	2.14	2.39	2.39	2.38	2.40	2.67	2.67	2.67	2.68	2.99	2.99	2.98	3.00	3.36	3.36	3.36	3.37
	Amps	7.6	7.6	7.6	7.7	8.7	8.7	8.6	8.7	9.9	9.9	9.8	9.9	11.2	11.2	11.1	11.2	12.6	12.6	12.6	12.7	14.3	14.3	14.3	14.4
	Hi/PR	251	253	254	259	291	292	294	298	332	333	335	339	376	377	379	383	424	425	427	431	475	476	478	482
Lo/PR	121	123	126	131	128	130	133	138	135	136	139	144	140	142	145	150	145	147	150	155	152	153	157	162	
1200	MBh	36.0	36.5	37.5	39.1	35.7	36.1	37.2	38.8	34.7	35.2	36.3	37.9	33.2	33.7	34.7	36.3	31.2	31.7	32.8	34.4	29.5	30.0	31.0	32.6
	S/T	0.82	0.75	0.61	0.47	0.83	0.76	0.62	0.48	1.00	0.78	0.64	0.50	1.00	0.80	0.66	0.52	1.00	0.82	0.69	0.54	1.00	1.00	0.74	0.60
	ΔT	22	20	17	13	22	20	17	13	22	20	17	13	22	20	17	13	22	20	16	13	23	21	18	14
	kW	1.90	1.90	1.89	1.91	2.13	2.13	2.13	2.15	2.40	2.40	2.39	2.41	2.68	2.68	2.68	2.69	3.00	3.00	2.99	3.01	3.37	3.37	3.37	3.38
	Amps	7.6	7.6	7.6	7.7	8.7	8.7	8.7	8.8	9.9	9.9	9.9	10.0	11.2	11.2	11.2	11.3	12.7	12.7	12.6	12.7	14.4	14.4	14.3	14.4
	Hi/PR	253	254	256	260	293	294	295	300	334	335	337	341	378	379	381	385	426	427	429	433	477	478	480	484
Lo/PR	123	124	127	132	130	132	135	140	136	138	141	146	142	143	146	151	147	149	152	157	154	155	158	163	
1350	MBh	36.7	37.2	38.2	39.8	36.4	36.9	37.9	39.5	35.5	36.0	37.0	38.6	33.9	34.4	35.4	37.0	32.0	32.5	33.5	35.1	30.2	30.7	31.8	33.4
	S/T	0.84	0.76	0.63	0.48	0.85	0.77	0.63	0.49	1.00	0.79	0.66	0.52	1.00	0.81	0.68	0.54	1.00	0.84	0.70	0.56	1.00	1.00	0.75	0.61
	ΔT	21	19	16	12	21	19	16	12	21	19	16	12	21	19	16	12	21	19	16	12	22	20	17	13
	kW	1.91	1.91	1.90	1.92	2.14	2.14	2.14	2.16	2.41	2.41	2.40	2.42	2.69	2.69	2.69	2.70	3.01	3.01	3.00	3.02	3.38	3.38	3.38	3.39
	Amps	7.7	7.7	7.7	7.7	8.8	8.8	8.7	8.8	10.0	10.0	9.9	10.0	11.3	11.3	11.2	11.3	12.7	12.7	12.7	12.8	14.4	14.4	14.4	14.5
	Hi/PR	256	257	258	263	295	296	298	302	336	337	339	343	380	382	383	388	428	429	431	435	479	480	482	486
Lo/PR	125	127	130	135	133	134	137	142	139	140	143	148	144	146	149	154	150	151	154	159	156	158	161	166	

IDB: Entering Indoor Dry Bulb Temperature
 High and low pressures are measured at the liquid and suction service valves.
 Shaded area reflects ACCA (TVA) conditions
 kW = Total system power
 Amps = outdoor unit amps (compressor + fan)

EXPANDED COOLING DATA — GSZC160361C* / CA*F3743*6D*+MBVC1600**-.1A*+TX — HIGH STAGE

IDB	AIRFLOW	OUTDOOR AMBIENT TEMPERATURE												115°F																	
		65°F						75°F						85°F						95°F						105°F					
		59	63	67	71	75	79	59	63	67	71	75	79	59	63	67	71	75	79	59	63	67	71	75	79	59	63	67	71	75	79
80	1080	MBh	35.7	36.2	37.2	38.8	35.3	35.8	36.9	38.5	34.4	34.9	36.0	37.6	32.9	33.4	34.4	36.0	30.9	31.4	32.5	34.1	29.2	29.7	30.7	32.3					
		S/T	0.92	0.84	0.71	0.56	1.00	0.85	0.71	0.57	1.00	0.87	0.74	0.60	1.00	0.89	0.76	0.62	1.00	1.00	0.78	0.64	1.00	1.00	0.83	0.69					
		ΔT	27	25	22	18	27	25	22	18	27	25	22	18	27	25	22	18	27	25	21	18	28	26	23	19					
		kW	1.89	1.89	1.89	1.90	2.13	2.12	2.12	2.14	2.39	2.39	2.38	2.40	2.67	2.67	2.67	2.69	2.99	2.99	2.98	3.00	3.36	3.36	3.36	3.38					
		Amps	7.6	7.6	7.6	7.7	8.7	8.7	8.7	8.7	9.9	9.9	9.9	9.9	11.2	11.2	11.2	11.2	12.6	12.6	12.6	12.7	14.3	14.3	14.3	14.4					
		Hi PR	252	253	255	259	291	292	294	298	332	333	335	340	377	378	380	384	425	426	427	432	476	477	478	483					
	Lo PR	122	123	126	131	129	130	133	139	135	137	140	145	141	142	145	150	146	147	150	156	153	154	157	162						
	1200	MBh	36.1	36.6	37.7	39.3	35.8	36.3	37.4	39.0	34.9	35.4	36.5	38.1	33.3	33.8	34.9	36.5	31.4	31.9	33.0	34.6	29.7	30.2	31.2	32.8					
		S/T	1.00	0.87	0.74	0.60	1.00	0.88	0.75	0.60	1.00	0.91	0.77	0.63	1.00	0.92	0.79	0.65	1.00	1.00	0.81	0.67	1.00	1.00	0.86	0.72					
		ΔT	26	24	21	17	26	24	21	17	26	24	21	17	26	24	21	17	26	24	21	17	27	25	22	18					
		kW	1.90	1.90	1.89	1.91	2.14	2.13	2.13	2.15	2.40	2.40	2.39	2.41	2.68	2.68	2.68	2.69	3.00	3.00	2.99	3.01	3.37	3.37	3.37	3.38					
		Amps	7.6	7.6	7.6	7.7	8.7	8.7	8.7	8.8	9.9	9.9	9.9	10.0	11.2	11.2	11.2	11.3	12.7	12.7	12.7	12.7	14.4	14.4	14.4	14.4					
Hi PR		254	255	257	261	293	294	296	300	334	335	337	341	379	380	381	386	426	427	429	434	477	478	480	485						
Lo PR	123	125	128	133	131	132	135	140	137	138	141	147	142	144	147	152	148	149	152	157	154	156	159	164							
1350	MBh	36.9	37.4	38.4	40.0	36.6	37.1	38.1	39.7	35.6	36.1	37.2	38.8	34.1	34.6	35.6	37.2	32.2	32.6	33.7	35.3	30.4	30.9	31.9	33.5						
	S/T	1.00	0.89	0.75	0.61	1.00	0.89	0.76	0.62	1.00	0.92	0.78	0.64	1.00	1.00	0.80	0.66	1.00	1.00	0.83	0.68	1.00	1.00	0.88	0.73						
	ΔT	25	23	20	16	25	23	20	16	25	24	20	17	25	23	20	16	25	23	20	16	26	24	21	17						
	kW	1.91	1.91	1.90	1.92	2.15	2.14	2.14	2.16	2.41	2.41	2.40	2.42	2.69	2.69	2.69	2.70	3.01	3.01	3.00	3.02	3.38	3.38	3.38	3.39						
	Amps	7.7	7.7	7.7	7.7	8.8	8.8	8.7	8.8	10.0	10.0	9.9	10.0	11.3	11.3	11.2	11.3	12.7	12.7	12.7	12.8	14.4	14.4	14.4	14.5						
	Lo PR	256	257	259	263	295	296	298	303	337	338	339	344	381	382	384	388	429	430	432	436	480	481	483	487						
85	1080	MBh	36.2	36.7	37.8	39.4	35.9	36.4	37.5	39.1	35.0	35.5	36.6	38.2	33.4	33.9	35.0	36.6	31.5	32.0	33.1	34.7	29.8	30.3	31.3	32.9					
		S/T	1.00	0.94	0.81	0.67	1.00	0.95	0.81	0.67	1.00	1.00	0.84	0.70	1.00	1.00	0.86	0.72	1.00	1.00	0.88	0.74	1.00	1.00	0.79						
		ΔT	31	29	25	22	31	29	25	22	31	29	25	22	31	29	25	22	30	28	25	21	31	30	26	23					
		kW	1.90	1.89	1.89	1.91	2.13	2.13	2.13	2.14	2.39	2.39	2.39	2.41	2.68	2.68	2.67	2.69	3.00	2.99	2.99	3.01	3.37	3.37	3.36	3.38					
		Amps	7.6	7.6	7.6	7.7	8.7	8.7	8.7	8.8	9.9	9.9	9.9	10.0	11.2	11.2	11.2	11.3	12.7	12.7	12.6	12.7	14.4	14.4	14.3	14.4					
		Hi PR	253	254	256	260	292	293	295	300	334	335	336	341	378	379	381	385	426	427	429	433	477	478	480	484					
	Lo PR	123	125	128	133	131	132	135	140	137	139	142	147	142	144	147	152	148	149	152	157	154	156	159	164						
	1200	MBh	36.7	37.2	38.3	39.9	36.4	36.9	38.0	39.6	35.5	36.0	37.0	38.6	33.9	34.4	35.5	37.1	32.0	32.5	33.6	35.2	30.3	30.8	31.8	33.4					
		S/T	1.00	0.98	0.84	0.70	1.00	0.98	0.85	0.70	1.00	1.00	0.87	0.73	1.00	1.00	0.89	0.75	1.00	1.00	0.91	0.77	1.00	1.00	0.82						
		ΔT	30	28	24	21	30	28	24	21	30	28	25	21	30	28	24	21	29	28	24	21	31	29	25	22					
		kW	1.90	1.90	1.90	1.92	2.14	2.14	2.13	2.15	2.40	2.40	2.40	2.41	2.69	2.69	2.68	2.70	3.00	3.00	3.00	3.02	3.38	3.38	3.37	3.39					
		Amps	7.7	7.7	7.6	7.7	8.7	8.7	8.7	8.8	9.9	9.9	9.9	10.0	11.2	11.2	11.2	11.3	12.7	12.7	12.7	12.8	14.4	14.4	14.4	14.5					
Hi PR		255	256	258	262	294	295	297	301	335	336	338	343	380	381	383	387	428	429	430	435	479	480	481	486						
Lo PR	125	127	130	135	132	134	137	142	139	140	143	148	144	146	149	154	149	151	154	159	156	158	161	166							
1350	MBh	37.5	38.0	39.0	40.6	37.2	37.6	38.7	40.3	36.2	36.7	37.8	39.4	34.7	35.2	36.2	37.8	32.7	33.2	34.3	35.9	31.0	31.5	32.5	34.1						
	S/T	1.00	0.99	0.85	0.71	1.00	1.00	0.86	0.72	1.00	1.00	0.89	0.74	1.00	1.00	0.90	0.76	1.00	1.00	0.93	0.78	1.00	1.00	0.84							
	ΔT	29	27	24	20	29	27	23	20	29	27	24	20	29	27	23	20	28	27	23	20	30	28	24	21						
	kW	1.91	1.91	1.91	1.93	2.15	2.15	2.14	2.16	2.41	2.41	2.41	2.42	2.70	2.70	2.69	2.71	3.01	3.01	3.01	3.03	3.39	3.39	3.38	3.40						
	Amps	7.7	7.7	7.7	7.8	8.8	8.8	8.8	8.8	10.0	10.0	10.0	10.0	11.3	11.3	11.3	11.3	12.7	12.7	12.7	12.8	14.4	14.4	14.4	14.5						
	Lo PR	257	258	260	264	297	298	299	304	338	339	341	345	382	383	385	389	430	431	433	437	481	482	484	488						

IDB: Entering Indoor Dry Bulb Temperature
 High and low pressures are measured at the liquid and suction service valves.
 Shaded area reflects AHRI (TVA) conditions
 kW = Total system power
 Amps = outdoor unit amps (compressor + fan)

IDB	AIRFLOW	OUTDOOR AMBIENT TEMPERATURE																							
		65°F				75°F				85°F				95°F				105°F				115°F			
		59	63	67	71	59	63	67	71	59	63	67	71	59	63	67	71	59	63	67	71	59	63	67	71
70	MBh	37.3	37.8	38.9	-	37.0	37.5	38.6	-	36.0	36.5	37.6	-	34.4	34.9	36.0	-	32.3	32.9	34.0	-	30.5	31.0	32.1	-
	S/T	0.63	0.56	0.43	-	0.64	0.57	0.44	-	0.66	0.59	0.46	-	1.00	0.61	0.48	-	1.00	0.63	0.50	-	1.00	0.68	0.55	-
	ΔT	20	18	15	-	20	18	15	-	21	19	15	-	20	18	15	-	20	18	14	-	21	19	16	-
	kW	1.44	1.44	1.44	-	1.63	1.62	1.62	-	1.83	1.83	1.83	-	2.06	2.05	2.05	-	2.30	2.30	2.30	-	2.60	2.60	2.59	-
	Amps	6.1	6.1	6.1	-	6.9	6.9	6.9	-	7.9	7.9	7.9	-	8.9	8.9	8.9	-	10.0	10.0	10.0	-	11.4	11.4	11.4	-
	Hi PR	201	202	203	-	233	234	235	-	266	266	268	-	301	302	303	-	339	340	342	-	380	381	383	-
	Lo PR	125	126	129	-	132	134	137	-	139	140	144	-	144	146	149	-	150	151	154	-	157	158	161	-
	MBh	38.2	38.7	39.8	-	37.8	38.4	39.5	-	36.9	37.4	38.5	-	35.2	35.7	36.8	-	33.2	33.7	34.8	-	31.4	31.9	33.0	-
	S/T	0.67	0.60	0.47	-	0.68	0.60	0.48	-	0.70	0.63	0.50	-	1.00	0.65	0.52	-	1.00	0.67	0.54	-	1.00	0.72	0.59	-
	ΔT	19	17	13	-	19	17	13	-	19	17	13	-	19	17	13	-	19	17	13	-	20	18	14	-
kW	1.45	1.45	1.45	-	1.64	1.63	1.63	-	1.84	1.84	1.84	-	2.07	2.06	2.06	-	2.32	2.31	2.31	-	2.61	2.61	2.60	-	
Amps	6.1	6.1	6.1	-	7.0	7.0	7.0	-	7.9	7.9	7.9	-	8.9	8.9	8.9	-	10.1	10.1	10.1	-	11.4	11.4	11.4	-	
Hi PR	204	204	206	-	235	236	237	-	268	269	270	-	303	304	306	-	342	343	344	-	383	383	385	-	
Lo PR	128	129	132	-	135	137	140	-	142	143	146	-	147	149	152	-	153	154	157	-	160	161	164	-	
MBh	39.1	39.6	40.7	-	38.7	39.3	40.4	-	37.8	38.3	39.4	-	36.1	36.6	37.7	-	34.1	34.6	35.7	-	32.3	32.8	33.9	-	
S/T	0.67	0.60	0.47	-	0.68	0.61	0.48	-	1.00	0.63	0.50	-	1.00	0.65	0.52	-	1.00	0.67	0.54	-	1.00	1.00	0.59	-	
ΔT	18	16	12	-	18	16	12	-	18	16	12	-	18	16	12	-	18	16	12	-	19	17	13	-	
kW	1.46	1.46	1.45	-	1.64	1.64	1.64	-	1.85	1.85	1.85	-	2.07	2.07	2.07	-	2.32	2.32	2.32	-	2.62	2.62	2.61	-	
Amps	6.2	6.2	6.1	-	7.0	7.0	7.0	-	8.0	8.0	7.9	-	9.0	9.0	9.0	-	10.1	10.1	10.1	-	11.5	11.5	11.4	-	
Hi PR	206	206	208	-	237	238	239	-	270	271	272	-	306	306	308	-	344	345	346	-	385	386	387	-	
Lo PR	131	132	135	-	138	140	143	-	145	146	149	-	150	152	155	-	156	157	160	-	162	164	167	-	

IDB	AIRFLOW	OUTDOOR AMBIENT TEMPERATURE																							
		65°F				75°F				85°F				95°F				105°F				115°F			
		59	63	67	71	59	63	67	71	59	63	67	71	59	63	67	71	59	63	67	71	59	63	67	71
75	MBh	37.3	37.9	39.0	40.6	37.0	37.5	38.6	40.3	36.0	36.6	37.7	39.3	34.4	34.9	36.0	37.7	32.4	32.9	34.0	35.7	30.5	31.0	32.1	33.8
	S/T	0.75	0.68	0.55	0.42	0.76	0.69	0.56	0.42	1.00	0.71	0.58	0.45	1.00	0.73	0.60	0.47	1.00	0.75	0.62	0.49	1.00	1.00	0.67	0.54
	ΔT	25	23	19	15	25	23	19	15	25	23	19	15	25	23	19	15	24	22	19	15	26	24	20	16
	kW	1.44	1.44	1.43	1.45	1.62	1.62	1.62	1.63	1.83	1.83	1.83	1.84	2.05	2.05	2.05	2.06	2.30	2.30	2.30	2.31	2.60	2.60	2.59	2.61
	Amps	6.1	6.1	6.1	6.1	6.9	6.9	6.9	7.0	7.9	7.9	7.8	7.9	8.9	8.9	8.9	8.9	10.0	10.0	10.0	10.1	11.4	11.4	11.4	11.4
	Hi PR	201	202	204	207	233	234	235	239	266	267	268	272	301	302	304	307	340	340	340	342	380	381	383	386
	Lo PR	125	126	129	135	132	134	137	142	139	140	144	149	144	146	149	154	150	151	155	160	157	158	161	167
	MBh	38.2	38.7	39.8	41.5	37.9	38.4	39.5	41.2	36.9	37.4	38.5	40.2	35.2	35.8	36.9	38.5	33.2	33.7	34.8	36.5	31.4	31.9	33.0	34.7
	S/T	0.79	0.72	0.59	0.46	1.00	0.73	0.60	0.46	1.00	0.75	0.62	0.49	1.00	0.77	0.64	0.50	1.00	0.79	0.66	0.53	1.00	1.00	0.71	0.57
	ΔT	23	21	18	14	23	21	18	14	24	22	18	14	23	21	18	14	23	21	17	13	24	22	19	15
kW	1.45	1.45	1.45	1.46	1.64	1.63	1.63	1.64	1.84	1.84	1.84	1.85	2.07	2.06	2.06	2.07	2.31	2.31	2.31	2.32	2.61	2.61	2.60	2.62	
Amps	6.1	6.1	6.1	6.2	7.0	7.0	7.0	7.1	7.9	7.9	7.9	8.0	8.9	8.9	8.9	9.0	10.1	10.1	10.1	10.1	11.4	11.4	11.4	11.5	
Hi PR	204	205	206	209	235	236	237	241	268	269	270	274	304	305	306	309	342	343	344	348	383	384	385	389	
Lo PR	128	129	132	138	135	137	140	145	142	143	146	152	147	149	152	157	153	154	157	163	160	161	164	169	
MBh	39.1	39.6	40.7	42.4	38.8	39.3	40.4	42.1	37.8	38.3	39.4	41.1	36.1	36.7	37.8	39.4	34.1	34.6	35.7	37.4	32.3	32.8	33.9	35.6	
S/T	0.79	0.72	0.59	0.46	1.00	0.73	0.60	0.46	1.00	0.75	0.62	0.49	1.00	0.77	0.64	0.51	1.00	1.00	0.66	0.53	1.00	1.00	0.71	0.58	
ΔT	22	20	17	13	22	20	17	13	23	21	17	13	22	20	17	13	22	20	16	12	23	21	18	14	
kW	1.46	1.46	1.45	1.47	1.64	1.64	1.64	1.65	1.85	1.85	1.85	1.86	2.07	2.07	2.07	2.08	2.32	2.32	2.32	2.33	2.62	2.61	2.61	2.63	
Amps	6.2	6.2	6.1	6.2	7.0	7.0	7.0	7.1	8.0	8.0	7.9	8.0	9.0	9.0	9.0	9.0	10.1	10.1	10.1	10.2	11.5	11.5	11.4	11.5	
Hi PR	206	207	208	211	237	238	239	243	270	271	272	276	306	307	308	311	344	345	346	350	385	386	387	391	
Lo PR	131	132	135	141	138	140	143	148	145	146	149	155	150	152	155	160	156	157	160	166	162	164	167	172	

IDB: Entering Indoor Dry Bulb Temperature
 High and low pressures are measured at the liquid and suction service valves.
 Shaded area reflects ACCA (TVA) conditions
 kW = Total system power
 Amps = outdoor unit amps (compressor + fan)

EXPANDED COOLING DATA — GSZC160481C*/CA*F4961*6D*+MBVC2000**~1A*+TX — LOW STAGE

IDB	AIRFLOW	OUTDOOR AMBIENT TEMPERATURE																								
		65°F				75°F				85°F				95°F				105°F				115°F				
		59	63	67	71	59	63	67	71	59	63	67	71	59	63	67	71	59	63	67	71	59	63	67	71	
80	1020	MBh	37.5	38.0	39.1	40.8	37.2	37.7	38.8	40.5	36.2	36.8	37.9	39.5	34.6	35.1	36.2	37.9	32.6	33.1	34.2	35.9	30.7	31.2	32.3	34.0
		S/T	1.00	0.80	0.67	0.54	1.00	0.81	0.68	0.54	1.00	0.83	0.70	0.57	1.00	1.00	0.72	0.58	1.00	1.00	0.74	0.61	1.00	1.00	0.79	0.65
		ΔT	29	27	23	20	29	27	23	20	29	27	24	20	29	27	23	20	29	27	23	19	30	28	24	21
		kW	1.44	1.44	1.44	1.45	1.63	1.62	1.62	1.63	1.83	1.83	1.83	1.84	2.06	2.05	2.05	2.06	2.30	2.30	2.30	2.31	2.60	2.60	2.59	2.61
		Amps	6.1	6.1	6.1	6.1	6.9	6.9	6.9	7.0	7.9	7.9	7.9	7.9	8.9	8.9	8.9	8.9	10.0	10.0	10.0	10.1	11.4	11.4	11.4	11.4
		Hi PR	202	203	204	207	233	234	235	239	266	267	268	272	302	303	304	307	340	341	342	346	381	382	383	387
		Lo PR	125	127	130	135	133	134	138	143	139	141	144	149	145	146	150	155	150	152	155	160	157	159	162	167
		MBh	38.4	38.9	40.0	41.7	38.0	38.6	39.7	41.3	37.1	37.6	38.7	40.4	35.4	36.0	37.1	38.7	33.4	33.9	35.0	36.7	31.6	32.1	33.2	34.9
		S/T	1.00	0.84	0.71	0.58	1.00	0.85	0.72	0.58	1.00	0.87	0.74	0.61	1.00	1.00	0.76	0.62	1.00	1.00	0.78	0.64	1.00	1.00	0.83	0.69
		ΔT	28	26	22	18	28	26	22	18	28	26	22	18	28	26	22	18	27	25	22	18	29	27	23	19
		kW	1.45	1.45	1.45	1.46	1.64	1.63	1.63	1.65	1.84	1.84	1.84	1.85	2.07	2.06	2.06	2.08	2.32	2.31	2.31	2.33	2.61	2.61	2.60	2.62
		Amps	6.1	6.1	6.1	6.2	7.0	7.0	7.0	7.0	7.9	7.9	7.9	8.0	8.9	8.9	8.9	9.0	10.1	10.1	10.1	10.1	11.4	11.4	11.4	11.5
Hi PR	204	205	206	210	236	236	238	241	269	269	271	274	304	305	306	310	342	343	345	348	383	384	385	389		
Lo PR	128	130	133	138	136	137	140	146	142	144	147	152	148	149	153	158	153	155	158	163	160	162	165	170		
MBh	39.3	39.8	40.9	42.6	38.9	39.5	40.6	42.2	38.0	38.5	39.6	41.3	36.3	36.9	38.0	39.6	34.3	34.8	35.9	37.6	32.5	33.0	34.1	35.8		
S/T	1.00	0.84	0.71	0.58	1.00	0.85	0.72	0.58	1.00	1.00	0.74	0.61	1.00	1.00	0.76	0.62	1.00	1.00	0.78	0.65	1.00	1.00	1.00	0.69		
ΔT	27	25	21	17	27	25	21	17	27	25	21	17	27	25	21	17	26	24	21	17	28	26	22	18		
kW	1.46	1.46	1.45	1.47	1.64	1.64	1.64	1.65	1.85	1.85	1.85	1.86	2.07	2.07	2.07	2.08	2.32	2.32	2.32	2.33	2.62	2.62	2.61	2.63		
Amps	6.2	6.2	6.1	6.2	7.0	7.0	7.0	7.1	8.0	8.0	7.9	8.0	9.0	9.0	9.0	9.0	10.1	10.1	10.1	10.2	11.5	11.5	11.4	11.5		
Hi PR	206	207	208	212	238	238	240	243	271	271	273	276	306	307	308	312	344	345	347	350	385	386	387	391		
Lo PR	131	133	136	141	139	140	143	149	145	147	150	155	151	152	155	161	156	158	161	166	163	165	168	173		
85	1020	MBh	38.1	38.7	39.8	41.4	37.8	38.3	39.4	41.1	36.9	37.4	38.5	40.2	35.2	35.7	36.8	38.5	33.2	33.7	34.8	36.5	31.3	31.9	33.0	34.6
		S/T	1.00	0.90	0.77	0.63	1.00	1.00	0.77	0.64	1.00	1.00	0.80	0.66	1.00	1.00	0.82	0.68	1.00	1.00	0.84	0.70	1.00	1.00	1.00	0.75
		ΔT	33	31	27	24	33	31	27	23	33	31	28	24	33	31	27	23	33	31	27	23	34	32	28	24
		kW	1.44	1.44	1.44	1.45	1.63	1.63	1.62	1.64	1.84	1.83	1.83	1.84	2.06	2.06	2.05	2.07	2.31	2.31	2.30	2.32	2.60	2.60	2.60	2.61
		Amps	6.1	6.1	6.1	6.1	6.9	6.9	6.9	7.0	7.9	7.9	7.9	7.9	8.9	8.9	8.9	9.0	10.1	10.0	10.0	10.1	11.4	11.4	11.4	11.4
		Hi PR	203	204	205	208	234	235	236	240	267	268	269	273	303	303	305	308	341	342	343	347	382	383	384	388
		Lo PR	127	129	132	137	135	136	139	145	141	143	146	151	147	148	151	157	152	154	157	162	159	161	164	169
		MBh	39.0	39.5	40.6	42.3	38.7	39.2	40.3	42.0	37.7	38.2	39.3	41.0	36.1	36.6	37.7	39.4	34.0	34.6	35.7	37.3	32.2	32.7	33.8	35.5
		S/T	1.00	0.94	0.81	0.67	1.00	1.00	0.81	0.68	1.00	1.00	0.84	0.70	1.00	1.00	0.86	0.72	1.00	1.00	0.74	0.60	1.00	1.00	1.00	0.79
		ΔT	32	30	26	22	32	30	26	22	32	30	26	22	32	30	26	22	31	29	26	22	33	31	27	23
		kW	1.45	1.45	1.45	1.46	1.64	1.64	1.64	1.65	1.85	1.84	1.84	1.86	2.07	2.07	2.06	2.08	2.32	2.32	2.31	2.33	2.61	2.61	2.61	2.62
		Amps	6.1	6.1	6.1	6.2	7.0	7.0	7.0	7.0	7.9	7.9	7.9	8.0	9.0	9.0	9.0	9.0	10.1	10.1	10.1	10.2	11.4	11.4	11.4	11.5
Hi PR	205	206	207	211	236	237	239	242	269	270	272	275	305	306	307	311	343	344	346	349	384	385	386	390		
Lo PR	130	132	135	140	138	139	142	148	144	146	149	154	150	151	154	160	155	157	160	165	162	163	167	172		
MBh	39.9	40.4	41.5	43.2	39.6	40.1	41.2	42.9	38.6	39.1	40.2	41.9	37.0	37.5	38.6	40.3	34.9	35.4	36.5	38.2	33.1	33.6	34.7	36.4		
S/T	1.00	0.94	0.81	0.67	1.00	1.00	0.81	0.68	1.00	1.00	0.84	0.70	1.00	1.00	0.86	0.72	1.00	1.00	0.74	0.60	1.00	1.00	1.00	0.79		
ΔT	31	29	25	21	31	29	25	21	31	29	25	21	31	29	25	21	30	28	25	21	32	30	26	22		
kW	1.46	1.46	1.46	1.47	1.65	1.65	1.64	1.66	1.85	1.85	1.85	1.86	2.08	2.08	2.07	2.09	2.33	2.33	2.32	2.34	2.62	2.62	2.62	2.63		
Amps	6.2	6.2	6.2	6.2	7.0	7.0	7.0	7.1	8.0	8.0	8.0	8.0	9.0	9.0	9.0	9.0	10.1	10.1	10.1	10.2	11.5	11.5	11.5	11.5		
Hi PR	207	208	209	213	239	239	241	244	271	272	274	277	307	308	309	313	345	346	348	351	386	387	388	392		
Lo PR	133	135	138	143	141	142	145	150	147	149	152	157	153	154	157	162	158	160	163	168	165	166	169	175		

IDB: Entering Indoor Dry Bulb Temperature
 High and low pressures are measured at the liquid and suction service valves.
 Shaded area reflects AHRI (TVA) conditions
 kW = Total system power
 Amps = outdoor unit amps (compressor + fan)

IDB		OUTDOOR AMBIENT TEMPERATURE																																			
		65°F						75°F						85°F						95°F						105°F						115°F					
		59	63	67	71	59	63	67	71	59	63	67	71	59	63	67	71	59	63	67	71	59	63	67	71	59	63	67	71								
70	1400	MBh	47.8	48.5	49.9	-	47.4	48.1	49.5	-	46.1	46.8	48.2	-	44.0	44.7	46.1	-	41.4	42.0	43.5	-	39.0	39.6	41.1	-											
		S/T	0.62	0.54	0.40	-	0.63	0.55	0.41	-	0.65	0.58	0.44	-	0.67	0.60	0.46	-	1.00	0.62	0.48	-	1.00	0.67	0.53	-											
	ΔT	19	18	14	-	19	18	14	-	20	18	15	-	19	18	14	-	19	17	14	-	20	18	15	-												
	kW	2.55	2.55	2.54	-	2.88	2.88	2.87	-	3.24	3.24	3.23	-	3.64	3.63	3.63	-	4.08	4.07	4.07	-	4.59	4.59	4.58	-												
	Amps	10.1	10.1	10.0	-	11.6	11.6	11.5	-	13.2	13.2	13.2	-	15.0	15.0	15.0	-	17.1	17.0	17.0	-	19.4	19.4	19.4	-												
	Hi PR	255	256	258	-	295	296	298	-	337	338	340	-	382	383	385	-	431	432	434	-	483	484	486	-												
	Lo PR	123	125	128	-	131	132	135	-	137	139	142	-	143	144	147	-	148	150	153	-	155	156	160	-												
	1600	MBh	48.4	49.1	50.5	-	48.0	48.7	50.1	-	46.8	47.4	48.9	-	44.6	45.3	46.7	-	42.0	42.7	44.1	-	39.6	40.3	41.7	-											
		S/T	0.68	0.61	0.47	-	0.69	0.61	0.47	-	0.72	0.64	0.50	-	1.00	0.66	0.52	-	1.00	0.68	0.54	-	1.00	0.73	0.59	-											
	ΔT	18	17	13	-	18	17	13	-	19	17	13	-	18	17	13	-	18	16	13	-	19	17	14	-												
kW	2.57	2.57	2.56	-	2.90	2.89	2.89	-	3.26	3.26	3.25	-	3.65	3.65	3.65	-	4.09	4.09	4.09	-	4.61	4.61	4.60	-													
Amps	10.2	10.1	10.1	-	11.7	11.6	11.6	-	13.3	13.3	13.3	-	15.1	15.1	15.1	-	17.1	17.1	17.1	-	19.5	19.5	19.5	-													
Hi PR	257	258	260	-	297	298	300	-	339	340	342	-	384	386	387	-	433	434	436	-	485	487	488	-													
Lo PR	125	126	130	-	132	134	137	-	139	140	144	-	144	146	149	-	150	151	155	-	157	158	161	-													
1800	MBh	49.2	49.9	51.3	-	48.8	49.4	50.9	-	47.5	48.2	49.6	-	45.4	46.1	47.5	-	42.7	43.4	44.9	-	40.4	41.0	42.5	-												
	S/T	0.72	0.64	0.50	-	0.72	0.65	0.51	-	0.75	0.67	0.53	-	1.00	0.69	0.55	-	1.00	0.71	0.58	-	1.00	0.77	0.63	-												
ΔT	17	16	12	-	17	16	12	-	18	16	13	-	17	16	12	-	17	15	12	-	18	16	13	-													
kW	2.58	2.58	2.58	-	2.91	2.91	2.90	-	3.27	3.27	3.27	-	3.67	3.66	3.66	-	4.11	4.10	4.10	-	4.62	4.62	4.62	-													
Amps	10.2	10.2	10.2	-	11.7	11.7	11.7	-	13.4	13.4	13.3	-	15.2	15.2	15.1	-	17.2	17.2	17.2	-	19.6	19.5	19.5	-													
Hi PR	259	260	262	-	299	300	302	-	341	342	344	-	387	388	389	-	435	437	438	-	488	489	490	-													
Lo PR	127	128	132	-	134	136	139	-	141	142	146	-	146	148	151	-	152	153	157	-	159	160	163	-													

IDB		OUTDOOR AMBIENT TEMPERATURE																																			
		65°F						75°F						85°F						95°F						105°F						115°F					
		59	63	67	71	59	63	67	71	59	63	67	71	59	63	67	71	59	63	67	71	59	63	67	71	59	63	67	71								
75	1400	MBh	47.8	48.5	49.9	52.1	47.4	48.1	49.5	51.7	46.2	46.8	48.3	50.5	44.0	44.7	46.1	48.3	41.4	42.1	43.5	45.7	39.0	39.7	41.1	43.3											
		S/T	0.75	0.68	0.54	0.39	0.76	0.68	0.54	0.40	1.00	0.71	0.57	0.42	1.00	0.73	0.59	0.44	1.00	0.75	0.61	0.47	1.00	1.00	0.66	0.52											
	ΔT	23	22	18	15	23	22	18	15	24	22	18	15	24	23	18	15	23	21	18	14	24	24	22	19	16											
	kW	2.55	2.55	2.54	2.57	2.88	2.87	2.87	2.89	3.24	3.24	3.23	3.26	3.63	3.63	3.63	3.65	4.07	4.07	4.07	4.09	4.59	4.59	4.58	4.61												
	Amps	10.1	10.1	10.0	10.1	11.6	11.6	11.5	11.6	13.2	13.2	13.2	13.3	15.0	15.0	15.0	15.1	17.0	17.0	17.0	17.1	19.4	19.4	19.4	19.5												
	Hi PR	255	256	258	262	295	296	298	302	337	338	340	344	382	384	385	390	431	432	434	439	484	485	486	491												
	Lo PR	123	125	128	133	131	132	135	141	137	139	142	147	143	144	147	153	148	150	153	158	155	156	160	165												
	1600	MBh	48.5	49.1	50.6	52.8	48.0	48.7	50.1	52.3	46.8	47.5	48.9	51.1	44.6	45.3	46.8	48.9	42.0	42.7	44.1	46.3	39.6	40.3	41.7	43.9											
		S/T	0.82	0.74	0.60	0.45	0.82	0.74	0.60	0.46	1.00	0.77	0.63	0.48	1.00	0.79	0.65	0.50	1.00	0.81	0.67	0.53	1.00	1.00	0.73	0.58											
	ΔT	22	21	17	14	22	20	17	14	23	21	17	14	23	22	17	14	22	20	17	13	23	23	21	18	15											
kW	2.57	2.56	2.56	2.58	2.89	2.89	2.89	2.91	3.26	3.25	3.25	3.27	3.65	3.65	3.64	3.67	4.09	4.09	4.08	4.11	4.61	4.60	4.60	4.62													
Amps	10.1	10.1	10.1	10.2	11.6	11.6	11.6	11.7	13.3	13.3	13.3	13.4	15.1	15.1	15.1	15.2	17.1	17.1	17.1	17.2	19.5	19.5	19.4	19.6													
Hi PR	257	258	260	264	297	298	300	305	339	340	342	347	385	386	388	392	434	435	436	441	486	487	489	493													
Lo PR	125	126	130	135	132	134	137	142	139	140	144	149	145	146	149	154	150	151	155	160	157	158	161	167													
1800	MBh	49.2	49.9	51.3	53.5	48.8	49.5	50.9	53.1	47.6	48.2	49.7	51.8	45.4	46.1	47.5	49.7	42.8	43.5	44.9	47.1	40.4	41.1	42.5	44.7												
	S/T	0.85	0.77	0.63	0.49	1.00	0.78	0.64	0.49	1.00	0.80	0.67	0.52	1.00	0.82	0.69	0.54	1.00	0.85	0.71	0.56	1.00	1.00	0.76	0.61												
ΔT	21	20	16	13	21	20	16	13	22	20	16	13	21	20	16	13	21	19	16	12	22	22	20	17	14												
kW	2.58	2.58	2.57	2.60	2.91	2.91	2.90	2.92	3.27	3.27	3.26	3.29	3.67	3.66	3.66	3.68	4.11	4.10	4.10	4.12	4.62	4.62	4.61	4.64													
Amps	10.2	10.2	10.2	10.3	11.7	11.7	11.7	11.8	13.4	13.4	13.3	13.4	15.2	15.2	15.1	15.3	17.2	17.2	17.2	17.3	19.5	19.5	19.5	19.6													
Hi PR	259	260	262	266	299	300	302	307	341	343	344	349	387	388	390	394	436	437	439	443	488	489	491	495													
Lo PR	127	128	132	137	134	136	139	144	141	143	146	151	147	148	151	156	152	153	157	162	159	160	163	169													

IDB: Entering Indoor Dry Bulb Temperature
 High and low pressures are measured at the liquid and suction service valves.
 Shaded area reflects ACCA (TVA) conditions
 kW = Total system power
 Amps = outdoor unit amps (compressor + fan)

IDB		OUTDOOR AMBIENT TEMPERATURE												115°F																	
		65°F						75°F						85°F						95°F						105°F					
		AIRFLOW		59	63	67	71	59	63	67	71	59	63	67	71	59	63	67	71	59	63	67	71	59	63	67	71				
80	1400	MBh	48.1	48.8	50.2	52.4	47.7	48.3	49.8	52.0	46.4	47.1	48.5	50.7	44.3	44.9	46.4	48.6	41.6	42.3	43.7	45.9	39.2	39.9	41.3	43.5					
		S/T	1.00	0.80	0.67	0.52	1.00	0.81	0.67	0.53	1.00	0.84	0.70	0.55	1.00	0.86	0.72	0.57	1.00	1.00	0.74	0.59	1.00	1.00	0.79	0.65					
		ΔT	27	26	22	19	27	26	22	19	28	26	22	19	27	26	22	19	27	25	22	18	28	26	23	20					
		KW	2.55	2.55	2.54	2.57	2.88	2.88	2.87	2.90	3.24	3.24	3.23	3.26	3.64	3.63	3.63	3.65	4.08	4.07	4.07	4.09	4.59	4.59	4.58	4.61					
		Amps	10.1	10.1	10.0	10.2	11.6	11.6	11.5	11.6	13.2	13.2	13.2	13.3	15.0	15.0	15.0	15.1	17.1	17.0	17.0	17.1	19.4	19.4	19.4	19.5					
		Hi PR	255	256	258	263	296	297	298	303	338	339	341	345	383	384	386	390	432	433	435	439	484	485	487	491					
	Lo PR	125	127	130	134	131	133	136	141	138	139	142	148	143	145	148	153	149	150	153	159	156	157	160	165						
	1600	MBh	48.7	49.4	50.8	53.0	48.3	49.0	50.4	52.6	47.0	47.7	49.1	51.3	44.9	45.6	47.0	49.2	42.3	42.9	44.4	46.6	39.9	40.5	42.0	44.2					
		S/T	1.00	0.87	0.73	0.58	1.00	0.87	0.73	0.59	1.00	0.90	0.76	0.61	1.00	1.00	0.78	0.63	1.00	1.00	0.80	0.66	1.00	1.00	0.85	0.71					
		ΔT	26	25	21	18	26	24	21	18	27	25	21	18	26	24	21	18	26	24	21	17	27	25	22	18					
		KW	2.57	2.57	2.56	2.59	2.90	2.89	2.89	2.91	3.26	3.26	3.25	3.28	3.65	3.65	3.64	3.67	4.09	4.09	4.08	4.11	4.61	4.61	4.60	4.63					
		Amps	10.2	10.1	10.1	10.2	11.6	11.6	11.6	11.7	13.3	13.3	13.3	13.4	15.1	15.1	15.1	15.2	17.1	17.1	17.1	17.2	19.5	19.5	19.5	19.6					
Hi PR		258	259	260	265	298	299	301	305	340	341	343	347	385	386	388	392	434	435	437	441	486	487	489	493						
Lo PR	127	129	132	137	133	134	138	143	140	141	144	149	145	147	150	155	151	152	155	160	157	159	162	167							
1800	MBh	49.5	50.2	51.6	53.8	49.0	49.7	51.2	53.3	47.8	48.5	49.9	52.1	45.7	46.3	47.8	49.9	43.0	43.7	45.1	47.3	40.6	41.3	42.7	44.9						
	S/T	1.00	0.90	0.76	0.62	1.00	0.91	0.77	0.62	1.00	0.93	0.79	0.65	1.00	1.00	0.81	0.67	1.00	1.00	0.84	0.69	1.00	1.00	0.89	0.74						
	ΔT	25	24	20	17	25	24	20	17	26	24	20	17	25	24	20	17	25	23	20	16	26	24	21	18						
	KW	2.58	2.58	2.58	2.60	2.91	2.91	2.90	2.93	3.27	3.27	3.27	3.29	3.67	3.66	3.66	3.68	4.11	4.10	4.10	4.12	4.62	4.62	4.62	4.64						
	Amps	10.2	10.2	10.2	10.3	11.7	11.7	11.7	11.8	13.4	13.4	13.3	13.5	15.2	15.2	15.1	15.3	17.2	17.2	17.2	17.3	19.6	19.5	19.5	19.6						
	Hi PR	260	261	263	267	300	301	303	307	342	343	345	349	387	388	390	395	436	437	439	443	488	489	491	496						
Lo PR	127	129	132	137	135	136	140	145	142	143	146	151	147	149	152	157	153	154	157	162	159	161	164	169							
85	1400	MBh	48.9	49.6	51.0	53.2	48.5	49.1	50.6	52.8	47.2	47.9	49.3	51.5	45.1	45.7	47.2	49.4	42.4	43.1	44.6	46.7	40.1	40.7	42.2	44.3					
		S/T	1.00	0.91	0.77	0.62	1.00	0.92	0.78	0.63	1.00	1.00	0.80	0.65	1.00	1.00	0.82	0.67	1.00	1.00	0.84	0.70	1.00	1.00	1.00	0.75					
		ΔT	31	29	26	22	31	29	26	22	31	29	26	23	31	29	26	22	31	29	25	22	32	30	27	23					
		KW	2.56	2.56	2.55	2.58	2.88	2.88	2.88	2.90	3.25	3.25	3.24	3.27	3.64	3.64	3.63	3.66	4.08	4.08	4.07	4.10	4.60	4.60	4.59	4.62					
		Amps	10.1	10.1	10.1	10.2	11.6	11.6	11.6	11.7	13.3	13.3	13.2	13.3	15.1	15.1	15.0	15.1	17.1	17.1	17.0	17.2	19.4	19.4	19.4	19.5					
		Hi PR	257	258	259	264	297	298	300	304	339	340	342	346	384	385	387	391	433	434	436	440	485	486	488	493					
	Lo PR	126	127	130	135	133	135	138	143	140	141	144	149	145	147	150	155	151	152	155	160	157	159	162	167						
	1600	MBh	49.5	50.2	51.6	53.8	49.1	49.8	51.2	53.4	47.8	48.5	50.0	52.1	45.7	46.4	47.8	50.0	43.1	43.8	45.2	47.4	40.7	41.4	42.8	45.0					
		S/T	1.00	0.97	0.83	0.68	1.00	1.00	0.84	0.69	1.00	1.00	0.86	0.72	1.00	1.00	0.88	0.74	1.00	1.00	0.91	0.76	1.00	1.00	1.00	0.81					
		ΔT	30	28	25	21	30	28	25	21	30	28	25	21	30	28	25	21	30	28	24	21	31	29	26	22					
		KW	2.58	2.57	2.57	2.59	2.90	2.90	2.89	2.92	3.27	3.26	3.26	3.28	3.66	3.66	3.65	3.68	4.10	4.10	4.09	4.12	4.62	4.61	4.61	4.63					
		Amps	10.2	10.2	10.1	10.3	11.7	11.7	11.6	11.8	13.3	13.3	13.3	13.4	15.1	15.1	15.1	15.2	17.2	17.1	17.1	17.2	19.5	19.5	19.5	19.6					
Hi PR		259	260	262	266	299	300	302	306	341	342	344	348	386	387	389	394	435	436	438	443	487	488	490	495						
Lo PR	127	129	132	137	135	136	139	145	141	143	146	151	147	148	152	157	152	154	157	162	159	161	164	169							
1800	MBh	50.3	51.0	52.4	54.6	49.9	50.5	52.0	54.1	48.6	49.3	50.7	52.9	46.5	47.1	48.6	50.7	43.8	44.5	45.9	48.1	41.4	42.1	43.5	45.7						
	S/T	1.00	1.00	0.87	0.72	1.00	1.00	0.87	0.73	1.00	1.00	0.90	0.75	1.00	1.00	0.92	0.77	1.00	1.00	1.00	0.79	1.00	1.00	1.00	0.85						
	ΔT	29	27	24	20	29	27	24	20	29	27	24	21	29	27	24	20	29	27	23	20	30	28	25	21						
	KW	2.59	2.59	2.58	2.61	2.92	2.91	2.91	2.93	3.28	3.28	3.27	3.30	3.67	3.67	3.67	3.69	4.11	4.11	4.11	4.13	4.63	4.63	4.62	4.65						
	Amps	10.2	10.2	10.2	10.3	11.7	11.7	11.7	11.8	13.4	13.4	13.4	13.5	15.2	15.2	15.2	15.3	17.2	17.2	17.2	17.3	19.6	19.6	19.5	19.7						
	Hi PR	261	262	264	268	301	302	304	308	343	344	346	350	388	390	391	396	437	438	440	445	489	491	492	497						
Lo PR	129	131	134	139	137	138	141	147	143	145	148	153	149	150	154	159	154	156	159	164	161	163	166	171							

IDB: Entering Indoor Dry Bulb Temperature
 High and low pressures are measured at the liquid and suction service valves.
 Shaded area reflects AHRI (TVA) conditions
 kW = Total system power
 Amps = outdoor unit amps (compressor + fan)

IDB	AIRFLOW	OUTDOOR AMBIENT TEMPERATURE																																			
		65°F						75°F						85°F						95°F						105°F						115°F					
		59	63	67	71	59	63	67	71	59	63	67	71	59	63	67	71	59	63	67	71	59	63	67	71	59	63	67	71	59	63	67	71				
70	1120	MBh	43.6	44.2	45.5	-	43.2	43.8	45.1	-	42.1	42.7	44.0	-	40.1	40.7	42.0	-	37.7	38.4	39.7	-	35.6	36.2	37.5	-	37.7	38.4	39.7	-	35.6	36.2	37.5	-			
		S/T	0.61	0.54	0.41	-	0.61	0.54	0.41	-	0.64	0.57	0.44	-	0.66	0.58	0.46	-	1.00	0.61	0.48	-	1.00	0.65	0.53	-	1.00	0.61	0.48	-	1.00	0.65	0.53	-			
		ΔT	21	19	15	-	21	19	15	-	21	19	15	-	21	19	15	-	21	19	15	-	22	20	16	-	21	19	15	-	22	20	16	-			
		KW	1.67	1.67	1.66	-	1.89	1.89	1.89	-	2.14	2.14	2.14	-	2.41	2.41	2.41	-	2.72	2.71	2.71	-	3.07	3.07	3.07	-	2.72	2.71	2.71	-	3.07	3.07	3.07	-			
		Amps	7.0	7.0	7.0	-	8.0	8.0	8.0	-	9.2	9.1	9.1	-	10.4	10.4	10.4	-	11.8	11.8	11.8	-	13.4	13.4	13.4	-	11.8	11.8	11.8	-	13.4	13.4	13.4	-			
	1200	Hi PR	200	201	203	-	232	233	234	-	265	266	267	-	300	301	303	-	339	340	341	-	380	380	382	-	339	340	341	-	380	380	382	-			
		Lo PR	120	122	125	-	128	129	132	-	134	136	139	-	139	141	144	-	145	146	149	-	151	153	156	-	145	146	149	-	151	153	156	-			
		MBh	43.9	44.5	45.8	-	43.5	44.1	45.4	-	42.4	43.0	44.3	-	40.4	41.1	42.3	-	38.1	38.7	40.0	-	35.9	36.5	37.8	-	38.1	38.7	40.0	-	35.9	36.5	37.8	-			
		S/T	0.64	0.56	0.43	-	0.64	0.57	0.44	-	0.67	0.59	0.46	-	0.68	0.61	0.48	-	1.00	0.63	0.50	-	1.00	0.68	0.55	-	1.00	0.63	0.50	-	1.00	0.68	0.55	-			
		ΔT	20	18	15	-	20	18	15	-	21	19	15	-	20	18	15	-	20	18	14	-	21	19	16	-	20	18	14	-	21	19	16	-			
1440	KW	1.69	1.69	1.68	-	1.91	1.91	1.91	-	2.16	2.16	2.16	-	2.43	2.43	2.43	-	2.74	2.74	2.73	-	3.09	3.09	3.09	-	2.74	2.74	2.73	-	3.09	3.09	3.09	-				
	Amps	7.1	7.1	7.0	-	8.1	8.1	8.1	-	9.3	9.2	9.2	-	10.5	10.5	10.5	-	11.9	11.9	11.9	-	13.5	13.5	13.5	-	11.9	11.9	11.9	-	13.5	13.5	13.5	-				
	Hi PR	201	202	204	-	233	234	235	-	266	267	268	-	301	302	304	-	340	340	342	-	380	381	383	-	340	340	342	-	380	381	383	-				
	Lo PR	121	123	126	-	129	130	133	-	135	136	140	-	140	142	145	-	146	147	150	-	152	154	157	-	146	147	150	-	152	154	157	-				
	MBh	45.1	45.7	47.0	-	44.7	45.3	46.6	-	43.5	44.2	45.5	-	41.6	42.2	43.5	-	39.2	39.8	41.1	-	37.0	37.7	39.0	-	39.2	39.8	41.1	-	37.0	37.7	39.0	-				

75	1120	MBh	43.6	44.2	45.5	47.5	43.2	43.8	45.1	47.1	42.1	42.7	44.0	46.0	40.2	40.8	42.1	44.0	37.8	38.4	39.7	41.7	35.6	36.2	37.5	39.5	37.8	38.4	39.7	41.7	35.6	36.2	37.5	39.5	
		S/T	0.73	0.66	0.53	0.39	0.74	0.67	0.54	0.40	1.00	0.69	0.56	0.42	1.00	0.71	0.58	0.44	1.00	0.73	0.60	0.46	1.00	0.78	0.65	0.51	1.00	1.00	0.73	0.60	0.46	1.00	0.78	0.65	0.51
		ΔT	25	23	20	16	25	23	20	16	26	24	20	16	25	23	20	16	25	23	19	15	24	22	20	17	26	25	23	19	15	26	24	20	17
		KW	1.67	1.66	1.66	1.68	1.89	1.89	1.88	1.90	2.14	2.14	2.14	2.15	2.41	2.41	2.41	2.42	2.72	2.71	2.71	2.73	3.07	3.07	3.07	3.08	3.07	2.72	2.71	2.71	2.73	3.07	3.07	3.07	3.08
		Amps	7.0	7.0	6.9	7.0	8.0	8.0	8.0	8.1	9.1	9.1	9.1	9.2	10.4	10.4	10.4	10.4	11.8	11.8	11.8	11.8	13.4	13.4	13.4	13.5	13.4	11.8	11.8	11.8	11.8	13.4	13.4	13.4	13.5
	1200	Hi PR	201	201	203	206	232	233	234	238	265	266	267	271	301	301	303	306	339	340	341	345	380	381	382	385	385	339	340	341	345	380	381	382	385
		Lo PR	120	122	125	130	128	129	132	137	134	136	139	144	139	141	144	149	145	146	149	154	151	153	156	161	161	145	146	149	154	151	153	156	161
		MBh	43.9	44.5	45.8	47.8	43.5	44.2	45.5	47.4	42.4	43.0	44.3	46.3	40.5	41.1	42.4	44.4	38.1	38.7	40.0	42.0	35.9	36.5	37.8	39.8	39.8	38.1	38.7	40.0	42.0	35.9	36.5	37.8	39.8
		S/T	0.76	0.69	0.56	0.42	0.77	0.69	0.56	0.43	1.00	0.72	0.59	0.45	1.00	0.73	0.61	0.47	1.00	0.76	0.63	0.49	1.00	0.81	0.68	0.54	1.00	1.00	0.76	0.63	0.49	1.00	0.81	0.68	0.54
		ΔT	25	23	19	15	25	23	19	15	25	23	19	15	25	23	19	15	24	22	19	15	26	24	20	16	26	24	22	19	15	26	24	20	16
1440	KW	1.67	1.67	1.67	1.68	1.90	1.89	1.89	1.91	2.15	2.14	2.14	2.16	2.42	2.42	2.41	2.43	2.72	2.72	2.72	2.73	3.08	3.07	3.07	3.09	3.09	2.72	2.72	2.72	2.73	3.08	3.07	3.07	3.09	
	Amps	7.0	7.0	7.0	7.1	8.0	8.0	8.0	8.1	9.2	9.1	9.2	9.2	10.4	10.4	10.5	10.5	11.8	11.8	11.8	11.9	13.4	13.4	13.4	13.5	13.5	11.8	11.8	11.8	11.9	13.4	13.4	13.4	13.5	
	Hi PR	201	202	204	207	233	234	235	239	266	267	268	272	301	302	304	307	340	341	342	345	381	381	383	386	386	340	341	342	345	381	381	383	386	
	Lo PR	121	123	126	131	129	130	133	138	135	136	140	145	140	142	145	150	155	146	147	150	155	152	154	157	162	162	146	147	150	155	152	154	157	162
	MBh	45.1	45.7	47.0	49.0	44.7	45.3	46.6	48.6	43.6	44.2	45.5	47.5	41.6	42.2	43.5	45.5	39.2	39.9	41.2	43.1	37.1	37.7	39.0	41.0	41.0	39.2	39.9	41.2	43.1	37.1	37.7	39.0	41.0	

IDB: Entering Indoor Dry Bulb Temperature
 High and low pressures are measured at the liquid and suction service valves.
 Shaded area reflects ACCA (TVA) conditions
 kW = Total system power
 Amps = outdoor unit amps (compressor + fan)

IDB	AIRFLOW	OUTDOOR AMBIENT TEMPERATURE												115°F																	
		65°F						75°F						85°F						95°F						105°F					
		59	63	67	71	75	79	59	63	67	71	75	79	59	63	67	71	75	79	59	63	67	71	75	79	59	63	67	71	75	79
80	MBh	43.8	44.5	45.8	47.7	43.5	44.1	45.4	47.3	42.3	42.9	44.2	46.2	40.4	41.0	42.3	44.3	38.0	38.6	39.9	41.9	35.8	36.4	37.7	39.7						
	S/T	0.85	0.78	0.65	0.51	1.00	0.79	0.66	0.52	1.00	0.81	0.68	0.54	1.00	0.83	0.70	0.56	1.00	1.00	1.00	0.72	0.58	1.00	1.00	0.77	0.63					
	ΔT	30	28	24	20	30	28	24	20	30	28	24	20	30	28	24	20	29	27	24	20	31	29	25	21						
	kW	1.67	1.66	1.66	1.68	1.89	1.89	1.89	1.90	2.14	2.14	2.14	2.15	2.41	2.41	2.41	2.42	2.72	2.71	2.71	2.71	3.07	3.07	3.07	3.08						
	Amps	7.0	7.0	7.0	7.0	8.0	8.0	8.0	8.1	9.2	9.1	9.1	9.2	10.4	10.4	10.4	10.4	11.8	11.8	11.8	11.8	13.4	13.4	13.4	13.5						
	Hi PR	201	202	203	207	232	233	235	238	265	266	268	271	301	302	303	307	339	340	341	345	380	381	382	386						
	Lo PR	122	122	125	131	128	130	133	138	135	136	139	144	140	141	145	150	145	147	150	155	152	153	156	162						
	MBh	44.2	44.8	46.1	48.0	43.8	44.4	45.7	47.7	42.6	43.3	44.5	46.5	40.7	41.3	42.6	44.6	38.3	38.9	40.2	42.2	36.1	36.8	38.0	40.0						
	S/T	0.88	0.81	0.68	0.54	1.00	0.81	0.68	0.55	1.00	0.84	0.71	0.57	1.00	0.85	0.73	0.59	1.00	1.00	0.75	0.61	1.00	1.00	0.80	0.66						
	ΔT	29	27	23	20	29	27	23	19	29	27	24	20	29	27	23	19	29	27	23	19	30	28	24	20						
kW	1.67	1.67	1.67	1.68	1.90	1.90	1.89	1.91	2.15	2.15	2.14	2.16	2.42	2.42	2.42	2.43	2.72	2.72	2.72	2.72	3.08	3.08	3.07	3.09							
Amps	7.0	7.0	7.0	7.1	8.0	8.0	8.0	8.1	9.2	9.2	9.2	9.2	10.4	10.4	10.4	10.5	11.8	11.8	11.8	11.9	13.4	13.4	13.4	13.5							
Hi PR	202	203	204	208	233	234	236	239	266	267	269	272	302	303	304	308	340	341	342	346	381	382	383	387							
Lo PR	122	123	126	132	129	131	134	139	136	137	140	145	141	142	145	151	146	148	151	156	153	154	157	162							
MBh	45.3	45.9	47.2	49.2	44.9	45.5	46.8	48.8	43.8	44.4	45.7	47.7	41.9	42.5	43.8	45.7	39.5	40.1	41.4	43.4	37.3	37.9	39.2	41.2							
S/T	1.00	0.85	0.72	0.58	1.00	0.85	0.72	0.59	1.00	0.88	0.75	0.61	1.00	1.00	0.77	0.63	1.00	1.00	0.79	0.65	1.00	1.00	0.84	0.70							
ΔT	28	26	22	18	27	25	22	18	28	26	22	18	27	25	22	18	27	25	21	18	28	26	23	19							
kW	1.69	1.69	1.68	1.70	1.91	1.91	1.91	1.92	2.16	2.16	2.16	2.17	2.43	2.43	2.43	2.45	2.74	2.74	2.73	2.75	3.09	3.09	3.09	3.10							
Amps	7.1	7.1	7.0	7.1	8.1	8.1	8.1	8.2	9.3	9.2	9.2	9.3	10.5	10.5	10.5	10.5	11.9	11.9	11.9	11.9	13.5	13.5	13.5	13.6							
Hi PR	204	205	207	210	236	237	238	242	269	270	271	275	304	305	307	310	343	344	345	348	384	384	386	389							
Lo PR	125	127	130	135	132	134	137	142	139	140	143	148	144	146	149	154	149	151	154	159	156	158	161	166							
85	MBh	44.6	45.2	46.5	48.5	44.2	44.8	46.1	48.1	43.1	43.7	45.0	46.9	41.1	41.7	43.0	45.0	38.7	39.3	40.6	42.6	36.6	37.2	38.5	40.4						
	S/T	1.00	0.88	0.75	0.61	1.00	0.88	0.75	0.62	1.00	1.00	0.78	0.64	1.00	1.00	0.79	0.66	1.00	1.00	0.82	0.68	1.00	1.00	0.87	0.73						
	ΔT	34	32	28	24	34	32	28	24	34	32	28	24	34	32	28	24	33	31	28	24	35	33	29	25						
	kW	1.67	1.67	1.67	1.68	1.90	1.89	1.89	1.91	2.15	2.14	2.14	2.16	2.42	2.42	2.41	2.43	2.72	2.72	2.72	2.73	3.08	3.07	3.07	3.09						
	Amps	7.0	7.0	7.0	7.1	8.0	8.0	8.0	8.1	9.2	9.2	9.1	9.2	10.4	10.4	10.4	10.5	11.8	11.8	11.8	11.9	13.4	13.4	13.4	13.5						
	Hi PR	202	203	204	208	233	234	236	239	266	267	269	272	302	303	304	308	340	341	342	346	381	382	383	387						
	Lo PR	123	124	127	132	130	131	135	140	136	138	141	146	142	143	146	151	147	149	152	157	154	155	158	163						
	MBh	44.9	45.5	46.8	48.8	44.5	45.1	46.4	48.4	43.4	44.0	45.3	47.3	41.4	42.0	43.3	45.3	39.0	39.7	41.0	42.9	36.9	37.5	38.8	40.8						
	S/T	1.00	0.90	0.77	0.64	1.00	0.91	0.78	0.64	1.00	1.00	0.80	0.67	1.00	1.00	0.82	0.69	1.00	1.00	0.84	0.71	1.00	1.00	0.87	0.76						
	ΔT	33	31	27	23	33	31	27	23	33	31	28	24	33	31	27	23	33	31	27	23	34	32	28	24						
kW	1.68	1.68	1.67	1.69	1.90	1.90	1.90	1.91	2.15	2.15	2.15	2.16	2.42	2.42	2.42	2.43	2.73	2.72	2.72	2.74	3.08	3.08	3.08	3.09							
Amps	7.0	7.0	7.0	7.1	8.1	8.0	8.0	8.1	9.2	9.2	9.2	9.3	10.4	10.4	10.4	10.5	11.8	11.8	11.8	11.9	13.5	13.4	13.4	13.5							
Hi PR	203	204	205	208	234	235	236	240	267	268	269	273	303	304	305	308	341	342	343	347	382	383	384	388							
Lo PR	124	125	128	133	131	132	135	141	137	139	142	147	143	144	147	152	148	149	153	158	155	156	159	164							
MBh	46.0	46.7	48.0	49.9	45.7	46.3	47.6	49.5	44.5	45.1	46.4	48.4	42.6	43.2	44.5	46.5	40.2	40.8	42.1	44.1	38.0	38.6	39.9	41.9							
S/T	1.00	0.94	0.81	0.68	1.00	1.00	0.82	0.68	1.00	1.00	0.84	0.71	1.00	1.00	0.86	0.73	1.00	1.00	0.88	0.75	1.00	1.00	0.80	0.80							
ΔT	31	29	26	22	31	29	26	22	32	30	26	22	31	29	26	22	31	29	25	22	32	30	27	23							
kW	1.69	1.69	1.69	1.70	1.92	1.91	1.91	1.93	2.17	2.17	2.16	2.18	2.44	2.44	2.43	2.45	2.74	2.74	2.74	2.75	3.10	3.10	3.09	3.11							
Amps	7.1	7.1	7.1	7.1	8.1	8.1	8.1	8.2	9.3	9.3	9.2	9.3	10.5	10.5	10.5	10.6	11.9	11.9	11.9	12.0	13.5	13.5	13.5	13.6							
Hi PR	205	206	208	211	237	238	239	243	270	271	272	276	305	306	308	311	344	345	346	349	385	385	387	390							
Lo PR	127	128	131	137	134	136	139	144	141	142	145	150	146	147	150	156	151	153	156	161	158	159	162	167							

IDB: Entering Indoor Dry Bulb Temperature
 High and low pressures are measured at the liquid and suction service valves.
 Shaded area reflects AHRI (TVA) conditions
 kW = Total system power
 Amps = outdoor unit amps (compressor + fan)

IDB		OUTDOOR AMBIENT TEMPERATURE																							
		65°F				75°F				85°F				95°F				105°F				115°F			
		59	63	67	71	59	63	67	71	59	63	67	71	59	63	67	71	59	63	67	71	59	63	67	71
	AIRFLOW	57.4	58.2	59.9	-	56.9	57.7	59.4	-	55.4	56.2	57.9	-	52.8	53.6	55.3	-	49.6	50.4	52.2	-	46.7	47.6	49.3	-
1540	MBh	0.59	0.52	0.38	-	0.60	0.52	0.39	-	0.63	0.55	0.41	-	0.65	0.57	0.43	-	0.67	0.59	0.46	-	1.00	0.64	0.51	-
	S/T	20	18	15	-	20	18	15	-	20	18	15	-	20	18	15	-	20	18	14	-	21	19	15	-
	ΔT	3.20	3.20	3.19	-	3.60	3.60	3.59	-	4.05	4.05	4.04	-	4.54	4.54	4.53	-	5.09	5.08	5.08	-	5.73	5.72	5.72	-
	kW	12.6	12.6	12.6	-	14.5	14.4	14.4	-	16.5	16.5	16.5	-	18.8	18.7	18.7	-	21.2	21.2	21.2	-	24.2	24.2	24.1	-
	Amps	248	249	251	-	287	288	290	-	328	329	331	-	372	373	375	-	420	421	423	-	471	472	473	-
	Lo PR	116	118	121	-	124	125	128	-	130	131	134	-	135	137	139	-	140	142	145	-	147	148	151	-
70	MBh	58.2	59.0	60.8	-	57.7	58.5	60.3	-	56.2	57.0	58.8	-	53.6	54.5	56.2	-	50.5	51.3	53.0	-	47.6	48.4	50.1	-
	S/T	0.67	0.59	0.45	-	0.67	0.60	0.46	-	0.70	0.62	0.49	-	0.72	0.64	0.51	-	0.74	0.66	0.53	-	1.00	0.71	0.58	-
	ΔT	19	17	13	-	19	17	13	-	19	17	14	-	19	17	13	-	18	16	13	-	19	18	14	-
	kW	3.23	3.22	3.22	-	3.63	3.63	3.62	-	4.08	4.08	4.07	-	4.57	4.56	4.56	-	5.11	5.11	5.10	-	5.75	5.75	5.74	-
	Amps	12.7	12.7	12.7	-	14.6	14.6	14.5	-	16.6	16.6	16.6	-	18.9	18.9	18.8	-	21.4	21.3	21.3	-	24.3	24.3	24.2	-
	Hi PR	250	251	253	-	289	290	292	-	330	331	333	-	375	376	377	-	422	423	425	-	473	474	476	-
	Lo PR	118	120	123	-	126	127	130	-	132	133	136	-	137	138	141	-	142	144	147	-	149	150	153	-
1980	MBh	58.9	59.8	61.5	-	58.4	59.2	61.0	-	56.9	57.7	59.5	-	54.4	55.2	56.9	-	51.2	52.0	53.7	-	48.3	49.1	50.8	-
	S/T	0.70	0.62	0.48	-	0.70	0.63	0.49	-	0.73	0.65	0.52	-	0.75	0.67	0.53	-	1.00	0.69	0.56	-	1.00	0.74	0.61	-
	ΔT	18	16	13	-	18	16	13	-	18	16	13	-	18	16	13	-	18	16	12	-	19	17	13	-
	kW	3.24	3.24	3.23	-	3.64	3.64	3.63	-	4.09	4.09	4.08	-	4.58	4.58	4.57	-	5.13	5.12	5.12	-	5.76	5.76	5.75	-
	Amps	12.8	12.8	12.7	-	14.6	14.6	14.6	-	16.7	16.7	16.7	-	18.9	18.9	18.9	-	21.4	21.4	21.4	-	24.4	24.3	24.3	-
	Hi PR	252	253	255	-	291	292	294	-	332	333	335	-	376	377	379	-	424	425	427	-	475	476	477	-
	Lo PR	120	121	124	-	127	129	131	-	133	135	138	-	139	140	143	-	144	145	148	-	150	152	155	-

1540	MBh	57.4	58.2	59.9	62.6	56.9	57.7	59.4	62.0	55.4	56.2	57.9	60.5	52.8	53.6	55.3	58.0	49.7	50.5	52.2	54.8	46.8	47.6	49.3	51.9
	S/T	0.72	0.65	0.51	0.37	0.73	0.65	0.52	0.37	0.76	0.68	0.54	0.40	1.00	0.70	0.56	0.42	1.00	0.72	0.58	0.44	1.00	0.77	0.64	0.49
	ΔT	24	22	19	15	24	22	19	15	24	22	19	15	24	22	19	15	24	22	18	15	25	23	19	16
	kW	3.20	3.20	3.19	3.22	3.60	3.60	3.59	3.62	4.05	4.05	4.04	4.07	4.54	4.54	4.53	4.56	5.08	5.08	5.07	5.11	5.72	5.72	5.71	5.74
	Amps	12.6	12.6	12.6	12.7	14.5	14.4	14.4	14.5	16.5	16.5	16.5	16.6	18.7	18.7	18.7	18.8	21.2	21.2	21.2	21.3	24.2	24.1	24.1	24.3
	Hi PR	248	249	251	255	287	288	290	294	328	329	331	335	372	373	375	379	420	421	423	427	471	472	474	478
	Lo PR	117	118	121	126	124	125	128	133	130	131	134	139	135	137	140	144	140	142	145	150	147	148	151	156
1800	MBh	58.3	59.1	60.8	63.4	57.8	58.6	60.3	62.9	56.3	57.1	58.8	61.4	53.7	54.5	56.2	58.8	50.5	51.3	53.0	55.7	47.6	48.4	50.2	52.8
	S/T	0.80	0.72	0.58	0.44	0.80	0.73	0.59	0.45	0.83	0.75	0.62	0.47	1.00	0.77	0.63	0.49	1.00	0.79	0.66	0.51	1.00	0.84	0.71	0.57
	ΔT	23	21	17	14	23	21	17	14	23	21	18	14	23	21	17	14	22	20	17	14	23	22	18	15
	kW	3.22	3.22	3.21	3.24	3.63	3.62	3.62	3.65	4.08	4.07	4.07	4.10	4.56	4.56	4.55	4.59	5.11	5.11	5.10	5.13	5.75	5.74	5.74	5.77
	Amps	12.7	12.7	12.7	12.8	14.6	14.6	14.5	14.7	16.6	16.6	16.6	16.7	18.9	18.8	18.8	19.0	21.4	21.3	21.3	21.4	24.3	24.3	24.2	24.4
	Hi PR	250	252	253	258	290	291	292	297	331	332	333	338	375	376	378	382	422	423	425	430	473	474	476	480
	Lo PR	118	120	123	128	126	127	130	135	132	133	136	141	137	139	141	146	142	144	147	152	149	150	153	158
1980	MBh	59.0	59.8	61.5	64.1	58.5	59.3	61.0	63.6	57.0	57.8	59.5	62.1	54.4	55.2	56.9	59.5	51.2	52.0	53.8	56.4	48.3	49.2	50.9	53.5
	S/T	0.82	0.75	0.61	0.47	0.83	0.75	0.62	0.48	1.00	0.78	0.64	0.50	1.00	0.80	0.66	0.52	1.00	0.82	0.69	0.54	1.00	0.87	0.74	0.59
	ΔT	22	20	17	13	22	20	17	13	22	20	17	13	22	20	17	13	22	20	16	13	23	21	17	14
	kW	3.24	3.23	3.23	3.26	3.64	3.64	3.63	3.66	4.09	4.09	4.08	4.11	4.58	4.58	4.57	4.60	5.12	5.12	5.11	5.14	5.76	5.76	5.75	5.78
	Amps	12.8	12.8	12.7	12.9	14.6	14.6	14.6	14.7	16.7	16.7	16.6	16.8	18.9	18.9	18.9	19.0	21.4	21.4	21.4	21.5	24.3	24.3	24.3	24.4
	Hi PR	252	253	255	259	291	292	294	298	332	333	335	339	376	377	379	384	424	425	427	431	475	476	478	482
	Lo PR	120	121	124	129	127	129	132	136	133	135	138	143	139	140	143	148	144	145	148	153	150	152	155	160

Shaded area reflects ACCA (TVA) conditions

kW = Total system power
Amps = outdoor unit amps (compressor + fan)

IDB: Entering Indoor Dry Bulb Temperature
High and low pressures are measured at the liquid and suction service valves.

EXPANDED COOLING DATA — GSZC160601C* / CA*F4961*6D*+MBVC2000**-1A*+TX — HIGH STAGE

IDB		OUTDOOR AMBIENT TEMPERATURE										105°F										115°F										
		65°F					75°F					85°F					95°F					105°F					115°F					
		ENTERING INDOOR WET BULB TEMPERATURE					ENTERING INDOOR WET BULB TEMPERATURE					ENTERING INDOOR WET BULB TEMPERATURE					ENTERING INDOOR WET BULB TEMPERATURE					ENTERING INDOOR WET BULB TEMPERATURE										
AIRFLOW	59	63	67	71	59	63	67	71	59	63	67	71	59	63	67	71	59	63	67	71	59	63	67	71	59	63	67	71	59	63	67	71
1540	MBh	57.7	58.5	60.2	62.9	57.2	58.0	59.7	62.3	55.7	56.5	58.2	60.8	53.1	53.9	55.6	58.3	50.0	50.8	52.5	55.1	47.1	47.9	49.6	52.2							
	S/T	0.85	0.77	0.64	0.49	1.00	0.78	0.64	0.50	1.00	0.80	0.67	0.53	1.00	0.82	0.69	0.55	1.00	0.85	0.71	0.57	1.00	1.00	0.76	0.62							
	ΔT	28	26	23	19	28	26	23	19	28	26	23	19	28	26	23	19	28	26	22	19	29	27	24	20							
	kW	3.20	3.20	3.19	3.22	3.60	3.60	3.59	3.62	4.05	4.05	4.04	4.08	4.54	4.54	4.53	4.56	5.09	5.08	5.08	5.11	5.73	5.72	5.72	5.75							
	Amps	12.6	12.6	12.6	12.7	14.5	14.4	14.4	14.6	16.5	16.5	16.5	16.6	18.8	18.7	18.7	18.8	21.2	21.2	21.2	21.3	24.2	24.2	24.1	24.3							
1800	Hi PR	248	250	251	256	288	289	290	295	329	330	331	336	373	374	376	380	420	421	423	428	471	472	474	478							
	Lo PR	117	118	121	126	124	126	129	134	130	132	135	140	136	137	140	145	141	142	145	150	147	149	152	157							
	MBh	58.6	59.4	61.1	63.7	58.1	58.9	60.6	63.2	56.6	57.4	59.1	61.7	54.0	54.8	56.5	59.1	50.8	51.6	53.3	56.0	47.9	48.7	50.5	53.1							
	S/T	0.92	0.85	0.71	0.57	1.00	0.85	0.72	0.57	1.00	0.88	0.74	0.60	1.00	0.90	0.76	0.62	1.00	0.92	0.78	0.64	1.00	1.00	0.83	0.69							
	ΔT	27	25	21	18	27	25	21	18	27	25	22	18	27	25	21	18	26	24	21	18	27	26	22	19							
1980	kW	3.22	3.22	3.21	3.25	3.63	3.63	3.62	3.65	4.08	4.08	4.07	4.10	4.57	4.56	4.56	4.59	5.11	5.11	5.10	5.13	5.75	5.75	5.74	5.77							
	Amps	12.7	12.7	12.7	12.8	14.6	14.6	14.5	14.7	16.6	16.6	16.6	16.7	18.9	18.9	18.9	19.0	21.4	21.3	21.3	21.5	24.3	24.3	24.2	24.4							
	Hi PR	251	252	254	258	290	291	293	297	331	332	334	338	375	376	378	382	423	424	426	430	474	475	476	481							
	Lo PR	119	120	123	128	126	128	131	135	132	134	137	142	138	139	142	147	143	144	146	149	149	151	154	159							
	MBh	59.3	60.1	61.8	64.4	58.8	59.6	61.3	63.9	57.3	58.1	59.8	62.4	54.7	55.5	57.2	59.8	51.5	52.3	54.1	56.7	48.6	49.5	51.2	53.8							
1540	S/T	1.00	0.87	0.74	0.60	1.00	0.88	0.74	0.60	1.00	0.91	0.77	0.63	1.00	0.93	0.79	0.65	1.00	1.00	0.81	0.67	1.00	1.00	0.86	0.72							
	ΔT	26	24	21	17	26	24	21	17	26	24	21	17	26	24	21	17	26	24	20	17	27	25	21	18							
	kW	3.24	3.24	3.23	3.26	3.64	3.64	3.63	3.66	4.09	4.09	4.08	4.11	4.58	4.58	4.57	4.60	5.13	5.12	5.12	5.15	5.76	5.76	5.75	5.79							
	Amps	12.8	12.8	12.7	12.9	14.6	14.6	14.6	14.7	16.7	16.7	16.7	16.8	18.9	18.9	18.9	19.0	21.4	21.4	21.4	21.5	24.3	24.3	24.3	24.4							
	Lo PR	121	122	125	130	128	129	132	137	134	135	138	143	139	141	144	148	144	146	149	154	151	152	155	160							
1540	MBh	58.7	59.5	61.2	63.8	58.2	59.0	60.7	63.3	56.7	57.5	59.2	61.8	54.1	54.9	56.6	59.2	50.9	51.7	53.5	56.1	48.0	48.9	50.6	53.2							
	S/T	1.00	0.87	0.74	0.60	1.00	0.88	0.74	0.60	1.00	0.91	0.77	0.63	1.00	0.93	0.79	0.65	1.00	1.00	0.81	0.67	1.00	1.00	0.86	0.72							
	ΔT	31	30	26	23	31	30	26	23	32	30	26	23	31	30	26	23	31	29	26	22	32	30	27	24							
	kW	3.21	3.20	3.20	3.23	3.61	3.61	3.60	3.63	4.06	4.06	4.05	4.08	4.55	4.55	4.54	4.57	5.09	5.09	5.08	5.12	5.73	5.73	5.72	5.75							
	Amps	12.6	12.6	12.6	12.7	14.5	14.5	14.5	14.6	16.6	16.6	16.5	16.7	18.8	18.8	18.7	18.9	21.3	21.3	21.2	21.4	24.2	24.2	24.2	24.3							
1800	Hi PR	250	251	252	257	289	290	292	296	330	331	333	337	374	375	377	381	422	423	424	429	472	473	475	480							
	Lo PR	119	120	123	128	126	127	130	135	132	134	137	141	137	139	142	147	143	144	147	152	149	150	153	158							
	MBh	59.5	60.3	62.1	64.7	59.0	59.8	61.6	64.2	57.5	58.3	60.1	62.7	54.9	55.8	57.5	60.1	51.8	52.6	54.3	56.9	48.9	49.7	51.4	54.1							
	S/T	1.00	0.95	0.81	0.67	1.00	0.95	0.82	0.67	1.00	1.00	0.84	0.70	1.00	1.00	0.86	0.72	1.00	1.00	0.88	0.74	1.00	1.00	0.94	0.79							
	ΔT	30	28	25	21	30	28	25	21	30	29	25	22	30	28	25	21	30	28	25	21	31	29	26	22							
1980	kW	3.23	3.23	3.22	3.25	3.64	3.63	3.63	3.66	4.09	4.08	4.08	4.11	4.57	4.57	4.56	4.60	5.12	5.12	5.11	5.14	5.76	5.75	5.75	5.78							
	Amps	12.8	12.7	12.7	12.9	14.6	14.6	14.6	14.7	16.7	16.7	16.6	16.8	18.9	18.9	18.9	19.0	21.4	21.4	21.3	21.5	24.3	24.3	24.3	24.4							
	Hi PR	252	253	255	259	291	292	294	298	332	333	335	339	376	377	379	384	424	425	427	431	475	476	478	482							
	Lo PR	121	122	125	130	128	129	132	137	134	136	138	143	139	141	144	149	145	146	149	154	151	152	155	160							
	MBh	60.2	61.1	62.8	65.4	59.7	60.5	62.3	64.9	58.2	59.0	60.8	63.4	55.7	56.5	58.2	60.8	52.5	53.3	55.0	57.6	49.6	50.4	52.1	54.8							
1980	S/T	1.00	0.98	0.84	0.70	1.00	0.98	0.85	0.70	1.00	1.00	0.87	0.73	1.00	1.00	0.89	0.75	1.00	1.00	0.91	0.77	1.00	1.00	0.96	0.82							
	ΔT	29	28	24	21	29	28	24	21	30	28	24	21	29	28	24	21	29	27	24	20	30	28	25	22							
	kW	3.25	3.24	3.24	3.27	3.65	3.65	3.64	3.67	4.10	4.10	4.09	4.12	4.59	4.59	4.58	4.61	5.13	5.13	5.12	5.15	5.77	5.77	5.76	5.79							
	Amps	12.8	12.8	12.8	12.9	14.7	14.7	14.6	14.8	16.7	16.7	16.7	16.8	19.0	19.0	18.9	19.1	21.5	21.4	21.4	21.6	24.4	24.4	24.3	24.5							
	Lo PR	254	255	257	261	293	294	296	300	334	335	337	341	378	379	381	385	426	427	428	433	476	478	479	484							

IDB: Entering Indoor Dry Bulb Temperature
 High and low pressures are measured at the liquid and suction service valves.
 Shaded area reflects AHRI (TVA) conditions
 kW = Total system power
 Amps = outdoor unit amps (compressor + fan)

GSZC160241C* / CA*F3137*6A*+MBVC1200**-1A*+TX — LOW STAGE

	OUTDOOR AMBIENT TEMPERATURE																
	65	60	55	50	47	45	40	35	30	25	20	17	15	10	5	0	-5
MBh	21.21	19.75	18.32	16.91	16.02	15.33	13.61	12.04	10.77	9.82	9.10	8.71	8.23	7.01	5.79	4.58	3.36
T/R	35.97	33.83	31.68	29.53	28.25	27.03	24.00	21.24	19.00	17.32	16.05	15.37	14.51	12.37	10.22	8.07	5.93
KW	1.03	1.01	0.98	0.96	0.94	0.93	0.90	0.88	0.85	0.83	0.80	0.79	0.78	0.75	0.72	0.70	0.67
AMPS	3.7	3.5	3.4	3.3	3.3	3.2	3.1	3.0	2.9	2.8	2.7	2.6	2.5	2.4	2.3	2.2	2.1
COP	6.02	5.75	5.48	5.19	4.99	4.83	4.41	4.02	3.70	3.48	3.33	3.25	3.11	2.74	2.34	1.92	1.46
Hi PR	362	350	339	327	320	315	303	292	280	268	256	249	244	233	221	209	197
LO PR	143	134	125	116	111	107	99	90	81	72	63	58	54	45	36	27	18

GSZC160241C* / CA*F3137*6A*+MBVC1200**-1A*+TX — HIGH STAGE

	OUTDOOR AMBIENT TEMPERATURE																
	65	60	55	50	47	45	40	35	30	25	20	17	15	10	5	0	-5
MBh	28.42	26.68	24.97	23.29	22.20	21.41	19.43	17.56	16.03	14.91	14.09	13.65	13.08	11.66	10.23	8.81	7.38
T/R	28.12	26.65	25.19	23.72	22.84	22.05	19.99	18.07	16.49	15.34	14.50	14.04	13.46	11.99	10.52	9.06	7.59
KW	1.68	1.66	1.65	1.64	1.63	1.62	1.61	1.59	1.58	1.56	1.55	1.54	1.53	1.52	1.50	1.49	1.47
AMPS	5.9	5.8	5.7	5.7	5.6	5.6	5.6	5.5	5.4	5.4	5.3	5.3	5.2	5.2	5.1	5.0	5.0
COP	4.96	4.70	4.44	4.17	4.00	3.87	3.55	3.23	2.98	2.80	2.67	2.60	2.50	2.25	1.99	1.73	1.47
Hi PR	374	362	349	337	330	325	313	301	289	277	264	257	252	240	228	216	204
LO PR	146	137	127	118	113	109	100	91	82	73	64	59	55	46	37	28	19

GSZC160361C* / CA*F3743*6D*+MBVC1600**-1A*+TX — LOW STAGE

	OUTDOOR AMBIENT TEMPERATURE																
	65	60	55	50	47	45	40	35	30	25	20	17	15	10	5	0	-5
MBh	32.21	30.06	27.94	25.86	24.53	23.52	21.00	18.69	16.81	15.40	14.35	13.79	13.07	11.28	9.50	7.71	5.92
T/R	38.24	36.03	33.82	31.61	30.28	29.04	25.92	23.07	20.75	19.02	17.72	17.03	16.14	13.93	11.72	9.51	7.30
KW	1.75	1.70	1.64	1.59	1.56	1.53	1.48	1.42	1.37	1.31	1.26	1.22	1.20	1.15	1.09	1.04	0.98
AMPS	6.4	6.2	6.0	5.7	5.6	5.5	5.2	5.0	4.8	4.5	4.3	4.1	4.0	3.8	3.6	3.3	3.1
COP	5.38	5.18	4.98	4.77	4.62	4.49	4.16	3.85	3.60	3.44	3.34	3.30	3.19	2.88	2.55	2.18	1.77
Hi PR	415	401	388	374	366	361	347	334	320	307	293	285	280	266	253	239	226
LO PR	134	126	117	109	104	101	92	84	76	67	59	54	51	42	34	26	17

GSZC160361C* / CA*F3743*6D*+MBVC1600**-1A*+TX — HIGH STAGE

	OUTDOOR AMBIENT TEMPERATURE																
	65	60	55	50	47	45	40	35	30	25	20	17	15	10	5	0	-5
MBh	43.10	40.55	38.05	35.59	34.00	32.84	30.01	27.28	25.04	23.40	22.23	21.60	20.77	18.71	16.64	14.57	12.51
T/R	35.53	33.76	31.99	30.21	29.15	28.21	25.73	23.39	21.47	20.07	19.06	18.52	17.81	16.04	14.27	12.49	10.72
KW	2.87	2.82	2.77	2.72	2.69	2.67	2.62	2.58	2.53	2.48	2.43	2.40	2.38	2.33	2.28	2.23	2.18
AMPS	10.8	10.6	10.3	10.1	10.0	9.9	9.7	9.5	9.3	9.1	8.8	8.7	8.6	8.4	8.2	8.0	7.8
COP	4.40	4.21	4.02	3.83	3.70	3.60	3.35	3.10	2.91	2.77	2.68	2.64	2.56	2.35	2.14	1.91	1.68
Hi PR	428	414	400	386	378	372	359	345	331	317	303	294	289	275	261	247	233
LO PR	137	128	120	111	106	103	94	86	77	69	60	55	52	43	35	26	18

Calculations are based on nominal CFM and 70 °F indoor dry bulb.

Amps = Outdoor unit amps (comp.+fan)

Note: Shaded area is AHRI Rating Conditions at 47°F outdoor ambient temperature

kW = Total system power

GSZC160481C* / CA*F4961*6D*+MBVC2000**-1A*+TX — LOW STAGE

	OUTDOOR AMBIENT TEMPERATURE																
	65	60	55	50	47	45	40	35	30	25	20	17	15	10	5	0	-5
MBh	44.95	41.85	38.81	35.81	33.91	32.44	28.78	25.46	22.76	20.74	19.21	18.39	17.35	14.77	12.18	9.59	7.01
T/R	40.84	38.39	35.95	33.50	32.04	30.65	27.19	24.06	21.51	19.59	18.15	17.37	16.39	13.95	11.51	9.06	6.62
KW	2.12	2.10	2.07	2.05	2.03	2.02	1.99	1.97	1.94	1.92	1.89	1.87	1.86	1.84	1.81	1.79	1.76
AMPS	7.7	7.6	7.5	7.3	7.3	7.2	7.1	7.0	6.9	6.8	6.7	6.6	6.5	6.4	6.3	6.2	6.1
COP	6.20	5.85	5.49	5.13	4.89	4.71	4.23	3.79	3.44	3.17	2.98	2.88	2.73	2.35	1.97	1.57	1.17
Hi PR	393	380	367	354	347	341	329	316	303	290	278	270	265	252	239	227	214
LO PR	129	121	113	105	100	97	89	81	73	65	57	52	49	41	33	25	17

GSZC160481C* / CA*F4961*6D*+MBVC2000**-1A*+TX — HIGH STAGE

	OUTDOOR AMBIENT TEMPERATURE																
	65	60	55	50	47	45	40	35	30	25	20	17	15	10	5	0	-5
MBh	60.24	56.53	52.89	49.31	47.00	45.33	41.10	37.13	33.87	31.48	29.74	28.80	27.59	24.55	21.52	18.49	15.45
T/R	33.52	31.77	30.01	28.25	27.20	26.25	23.79	21.48	19.60	18.22	17.21	16.67	15.96	14.21	12.45	10.70	8.94
KW	3.42	3.45	3.47	3.50	3.51	3.52	3.55	3.58	3.60	3.63	3.65	3.67	3.68	3.71	3.73	3.76	3.78
AMPS	12.3	12.4	12.6	12.7	12.7	12.8	12.9	13.0	13.1	13.2	13.3	13.4	13.5	13.6	13.7	13.8	13.9
COP	5.16	4.81	4.46	4.13	3.92	3.77	3.39	3.04	2.76	2.54	2.38	2.30	2.20	1.94	1.69	1.44	1.20
Hi PR	405	392	379	366	358	352	339	326	313	300	286	279	273	260	247	234	221
LO PR	131	123	115	107	102	99	91	82	74	66	58	53	50	41	33	25	17

GSZC160601C* / CA*F4961*6D*+MBVC2000**-1A*+TX — LOW STAGE

	OUTDOOR AMBIENT TEMPERATURE																
	65	60	55	50	47	45	40	35	30	25	20	17	15	10	5	0	-5
MBh	57.01	53.11	49.45	45.46	42.92	40.93	36.01	31.58	27.98	25.27	23.20	22.09	20.70	17.23	13.76	10.28	6.81
T/R	46.24	43.34	40.44	37.55	35.81	34.14	30.03	26.34	23.34	21.08	19.35	18.43	17.27	14.37	11.47	8.58	5.68
KW	2.89	2.82	2.76	2.69	2.65	2.62	2.56	2.49	2.42	2.36	2.29	2.25	2.23	2.16	2.09	2.03	1.96
AMPS	10.8	10.5	10.2	9.9	9.8	9.6	9.4	9.1	8.8	8.5	8.2	8.0	7.9	7.6	7.3	7.0	6.8
COP	5.78	5.51	5.26	4.95	4.75	4.57	4.13	3.71	3.38	3.14	2.97	2.88	2.73	2.34	1.93	1.49	1.02
Hi PR	445	431	416	402	393	387	373	358	344	329	315	306	300	286	272	257	243
LO PR	132	123	115	107	102	99	91	83	74	66	58	53	50	42	33	25	17

GSZC160601C* / CA*F4961*6D*+MBVC2000**-1A*+TX — HIGH STAGE

	OUTDOOR AMBIENT TEMPERATURE																
	65	60	55	50	47	45	40	35	30	25	20	17	15	10	5	0	-5
MBh	77.42	72.40	67.46	62.61	59.50	57.20	51.36	45.97	41.58	38.31	35.90	34.60	32.94	28.79	24.64	20.49	16.34
T/R	40.55	38.29	36.03	33.77	32.41	31.15	27.97	25.04	22.65	20.87	19.55	18.85	17.94	15.68	13.42	11.16	8.90
KW	4.70	4.67	4.64	4.61	4.59	4.58	4.55	4.52	4.49	4.46	4.43	4.41	4.40	4.37	4.34	4.31	4.28
AMPS	17.7	17.6	17.5	17.3	17.3	17.2	17.1	16.9	16.8	16.7	16.5	16.5	16.4	16.3	16.2	16.0	15.9
COP	4.83	4.55	4.26	3.98	3.80	3.66	3.31	2.98	2.72	2.52	2.38	2.30	2.20	1.93	1.67	1.39	1.12
Hi PR	460	445	430	415	406	400	385	370	355	340	325	316	310	295	280	265	250
LO PR	134	126	117	109	104	101	92	84	76	67	59	54	51	42	34	26	17

Calculations are based on nominal CFM and 70 °F indoor dry bulb.

Note: Shaded area is AHRI Rating Conditions at 47°F outdoor ambient temperature

Amps = Outdoor unit amps (comp.+fan)

kW = Total system power

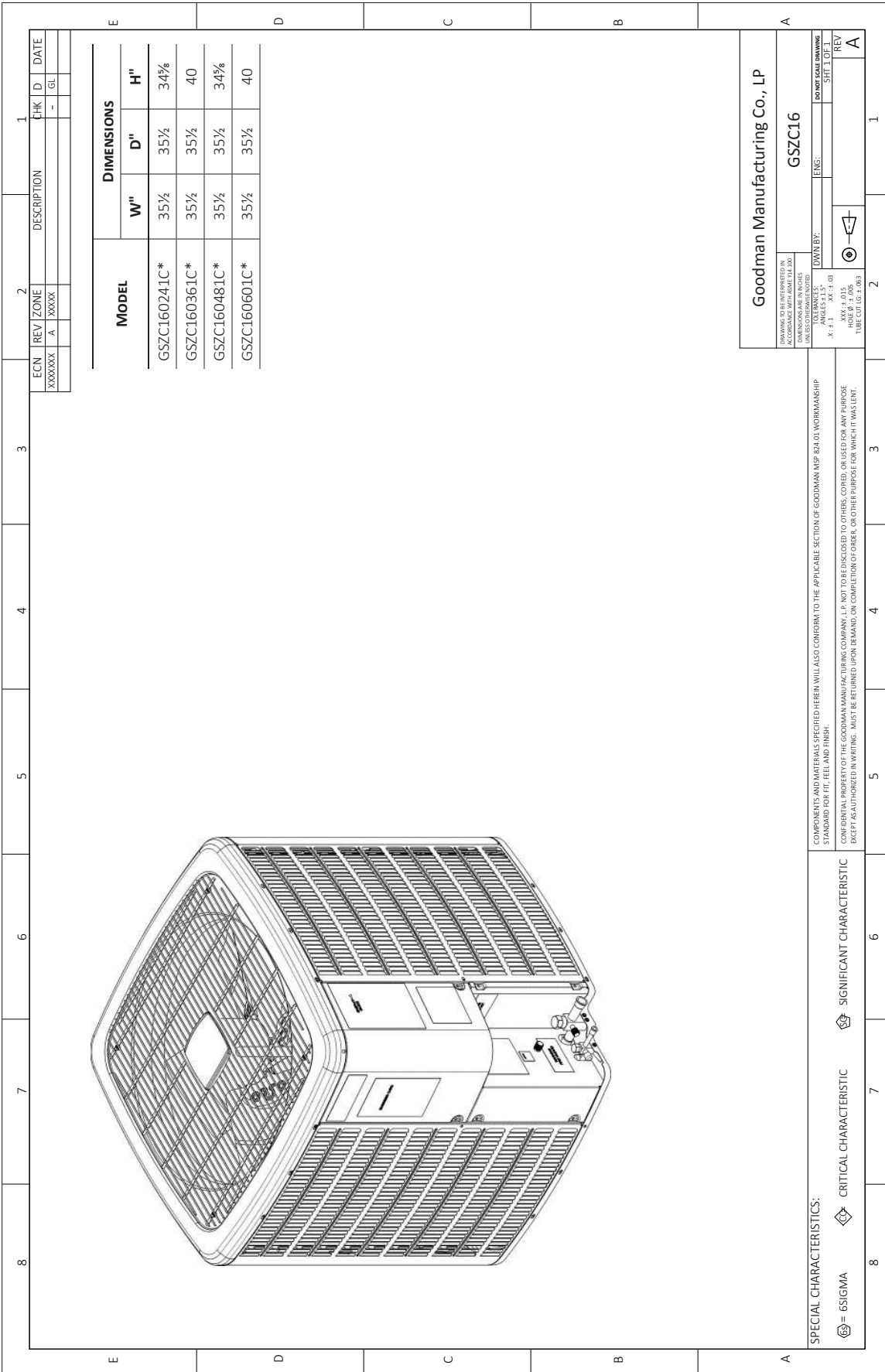

Goodman Manufacturing Co., LP
GSZC16
DRAWING TO BE INTERPRETED IN ACCORDANCE WITH ASHRAE 1.4.1.1.01 DIMENSIONS AND FINISHES UNLESS OTHERWISE SPECIFIED
 TOLERANCES:
 .XXX ± .015
 .X ± .1
 .XX ± .1
 .XX ± .03
 HOLE Ø ± .005
 TUBE CUT ± .003
 DWN BY: _____
 ENGS: _____
 SHEET 1 OF 1
 REV A

SPECIAL CHARACTERISTICS:
 Ⓢ = 6SIGMA Ⓢ = CRITICAL CHARACTERISTIC Ⓢ = SIGNIFICANT CHARACTERISTIC
 COMPONENTS AND MATERIALS SPECIFIED HEREIN WILL ALSO CONFORM TO THE APPLICABLE SECTION OF GOODMAN MSP B24.01 WORKMANSHIP STANDARD FOR FIT, FEEL AND FINISH.
 CONFIDENTIAL PROPERTY OF THE GOODMAN MANUFACTURING COMPANY, L.P. NOT TO BE DISCLOSED TO OTHERS, COPIED, OR USED FOR ANY PURPOSE EXCEPT AS AUTHORIZED IN WRITING. MUST BE RETURNED UPON DEMAND, ON COMPLETION OF ORDER, OR OTHER PURPOSE FOR WHICH IT WAS LENT.

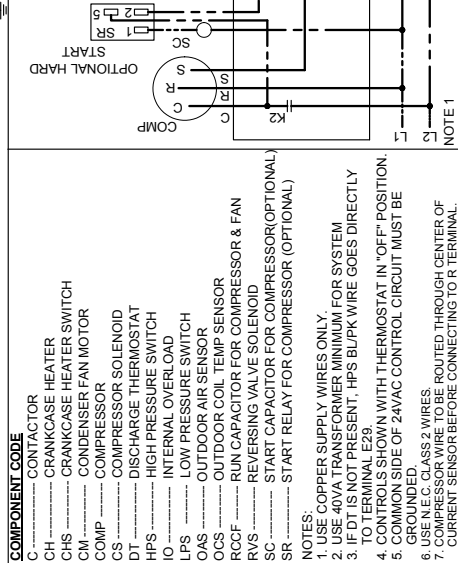
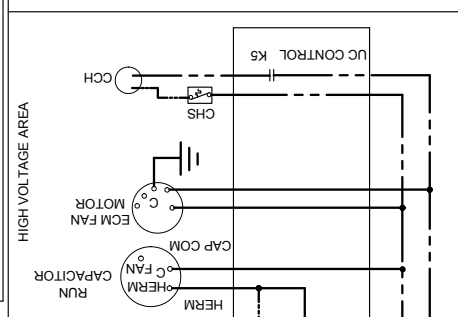
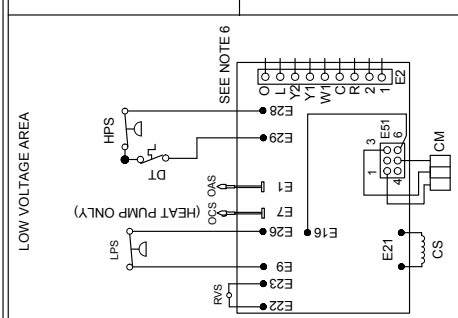
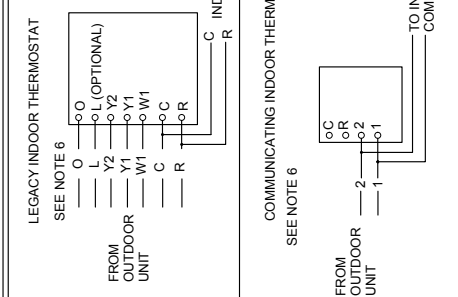
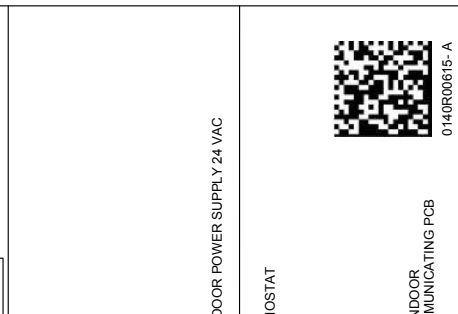
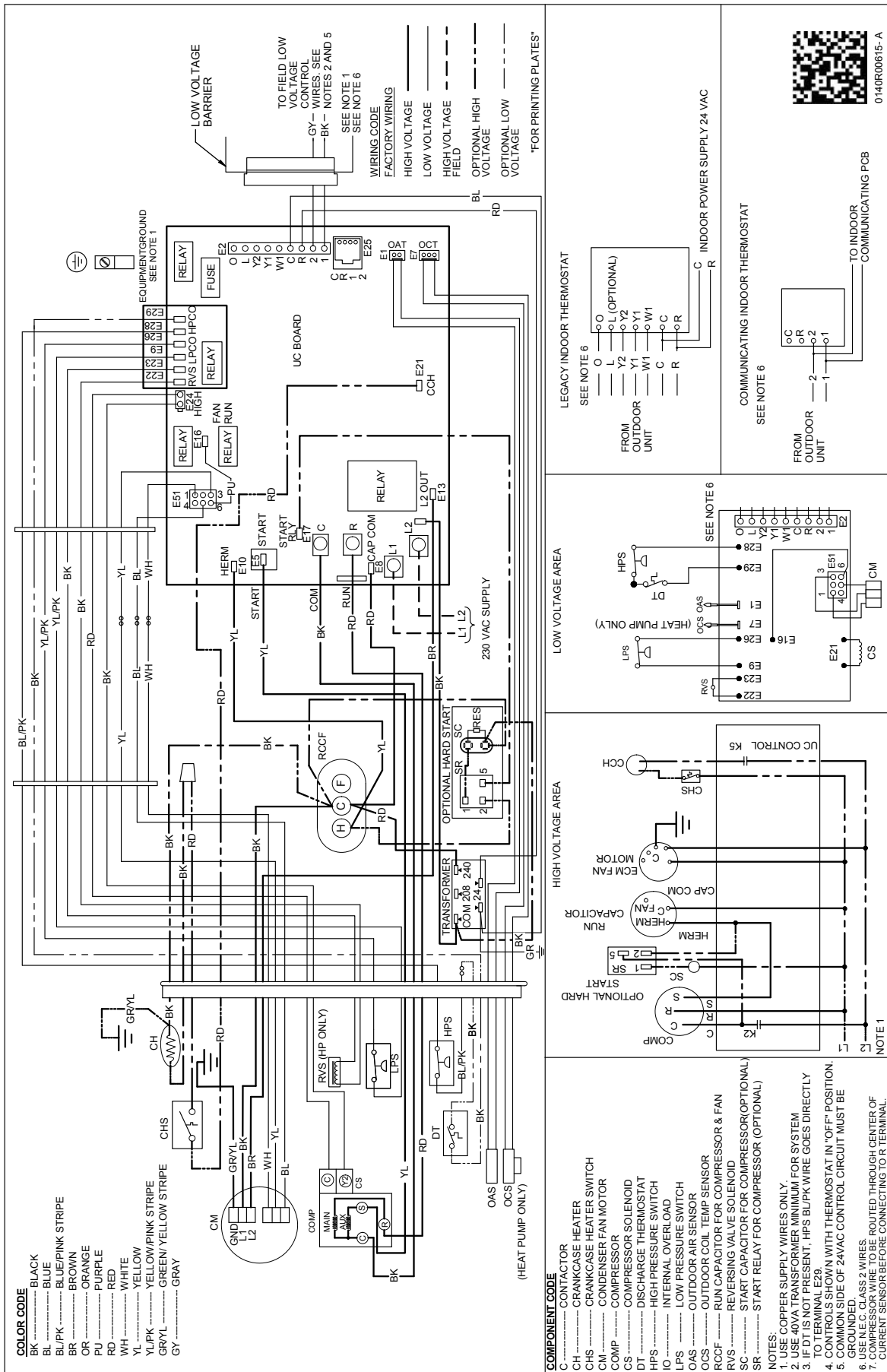

WARNING

High Voltage: Disconnect all power before servicing or installing this unit. Multiple power sources may be present. Failure to do so may cause property damage, personal injury, or death.

Wiring is subject to change. Always refer to the wiring diagram or the unit for the most up-to-date wiring.

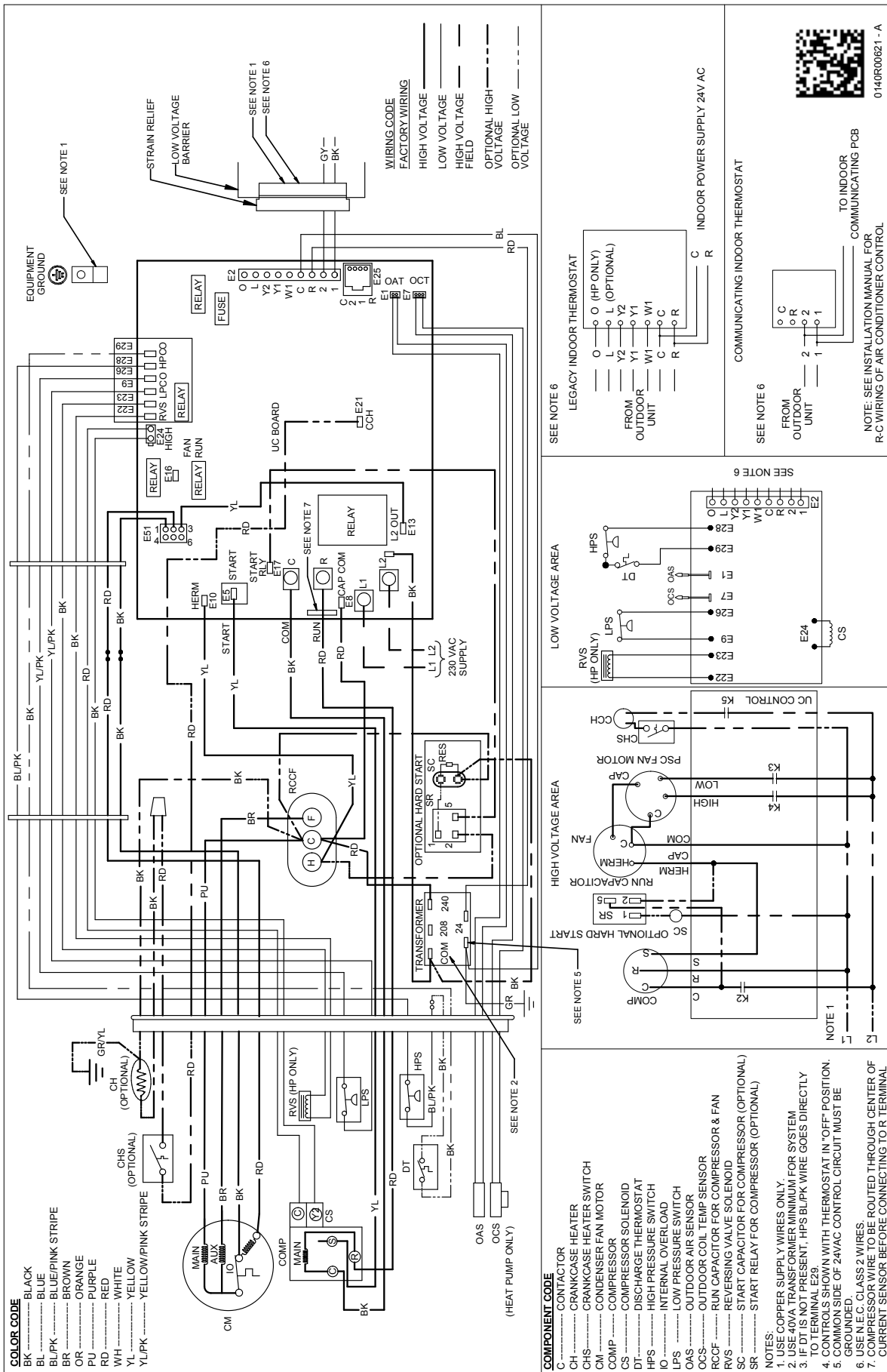

WARNING

High Voltage: Disconnect all power before servicing or installing this unit. Multiple power sources may be present. Failure to do so may cause property damage, personal injury, or death.

Wiring is subject to change. Always refer to the wiring diagram or the unit for the most up-to-date wiring.

MODEL	DESCRIPTION	GSZC16 024**	GSZC16 036**	GSZC16 048**	GSZC16 060**
ABK-20 ¹	Anchor Bracket Kit				
CSR-U-1	Hard-start Kit	X			
CSR-U-2	Hard-start Kit		X		
CSR-U-3	Hard-start Kit			X	X
FSK01A ²	Freeze Protection Kit	X	X	X	X
OT18-60A ³	Outdoor Thermostat/Lockout Thermostat	X	X	X	X
TX2N4 ⁴	TXV Kit				
TX2N4A ⁴	TXV Kit	X			
TX3N4 ⁴	TXV Kit		X		
TX5N4 ⁴	TXV Kit			X	X

Note: Maximum number of installed accessories at the same time is limited by the size of the unit's control box.

¹ Contains 20 brackets; four brackets needed to anchor unit to pad

² Installed on indoor coil

³ Available in 24V legacy mode only. This feature is integrated in the communicating mode. Required for heat pump applications where ambient temperature falls below 0 OF with 50% or higher relative humidity.

⁴ Condensing units and heat pumps with reciprocating or rotary compressors require the use of start-assist components when used in conjunction with an indoor coil using a non-bleed thermal expansion valve refrigerant metering device or liquid solenoid kit. The TXV should always be sized based on the tonnage of the outdoor unit.

All AHRI system ratings are accessible in the System Configurator tool via PartnerLink.